

Universal tele-programmable, tele-controllable protection and mains analysis unit with WebServer and Modbus TCP/IP
Automatic reclosures with built-in motor-drive. Graphic and numerical display in real time. RMS, Peak, AC and DC measurements
Differential I. protection and analysis, type A / B. RMS, Peak, AC and DC measurements. Auto-refreshing differential I. oscilloscope
Oscilloscope event-logger with pre-trigger, differential intensity channel (600-event built-in memory)
Oscilloscope event-logger with pre-trigger, voltage and intensity channels (600-event built-in memory)
Oscilloscope and 64-harmonic spectrum, 7 auto-refreshing channels (distortion range in % and V – A, + THD value)
THD measurement and alarm as from 2-63, programmable by harmonic and harmonics bracket
Proactive measurements of 1600 electrical parameters + temperature and humidity
Relays with alarms, timers, time programmer, input control and manual control
Graphical history (months, days, hours and minutes) of energy, costs and emissions with built-in 3-year memory
Tele-management, sizing, surveillance, energy maintenance and I/O control. Precisions: (V, I): $\pm 0.2\%$ and $\pm 0.4\%$

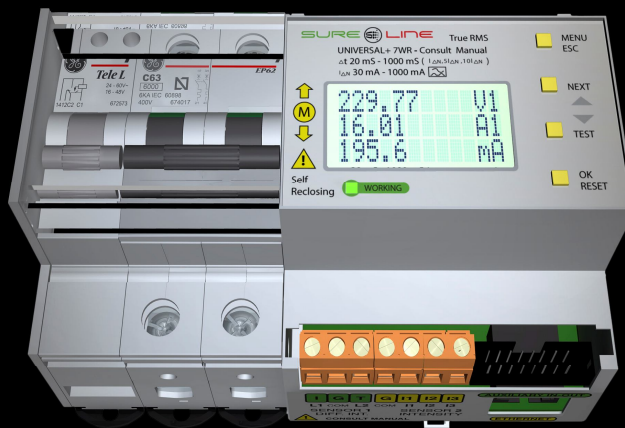

UNIVERSAL+ 7WR M1 Differential, type A
Built-in reclosure motor-drive command for MCB from 6 to 63A, 2 and 4-pole

Annex-manual - UNIVERSAL+ 7WR M1 Differential, type A
Software: version V3.15



SAFE  **LINE.SL**

Annexe to UNIVERSAL+ 7WR M1 Differential, type A user/installer manual

It is essential that the user/installer fully understand the present manual prior to using the unit. Should any doubt arise, please refer to the Authorised Distributor or the Manufacturer (Please, refer to UNIVERSAL+ 7WR M1, M2 and M3 Generic manual)

All rights reserved. No part of this publication may be reproduced, stored in a retrieval system, or transmitted in any form or by any means electronic, mechanical, recording or photocopying or otherwise without the express prior consent of Safeline, S.L. Whilst every care has been taken to ensure that the information contained herein is correct, no liability can be accepted by Safeline, S.L. for any damage caused by any errors in, or omissions from, the information given. Neither is Safeline, S.L. liable for any damage arising from the incorrect use of this information.

Safeline, S.L., as also its affiliates, is not liable to the purchaser or to third parties for damages, be they material or personal, costs, etc. in which the purchaser or third party may incur as a result of any accident or incorrect use of this product, nor as a result of any unauthorised modification, alteration or repair to same, nor due to non-observance of the operation and maintenance instructions given by Safeline, S.L.

Always with an aim to improving the quality of its products, Safeline reserves the right to modify, without previous notice, any standard or characteristic in the present manual and the products indicated herein. The technical characteristics set out in said standards are for information purposes.

Sureline is a trademark of Safeline, S.L.

Published in Spain by Safeline, S.L. 16th Edition (June 2020)

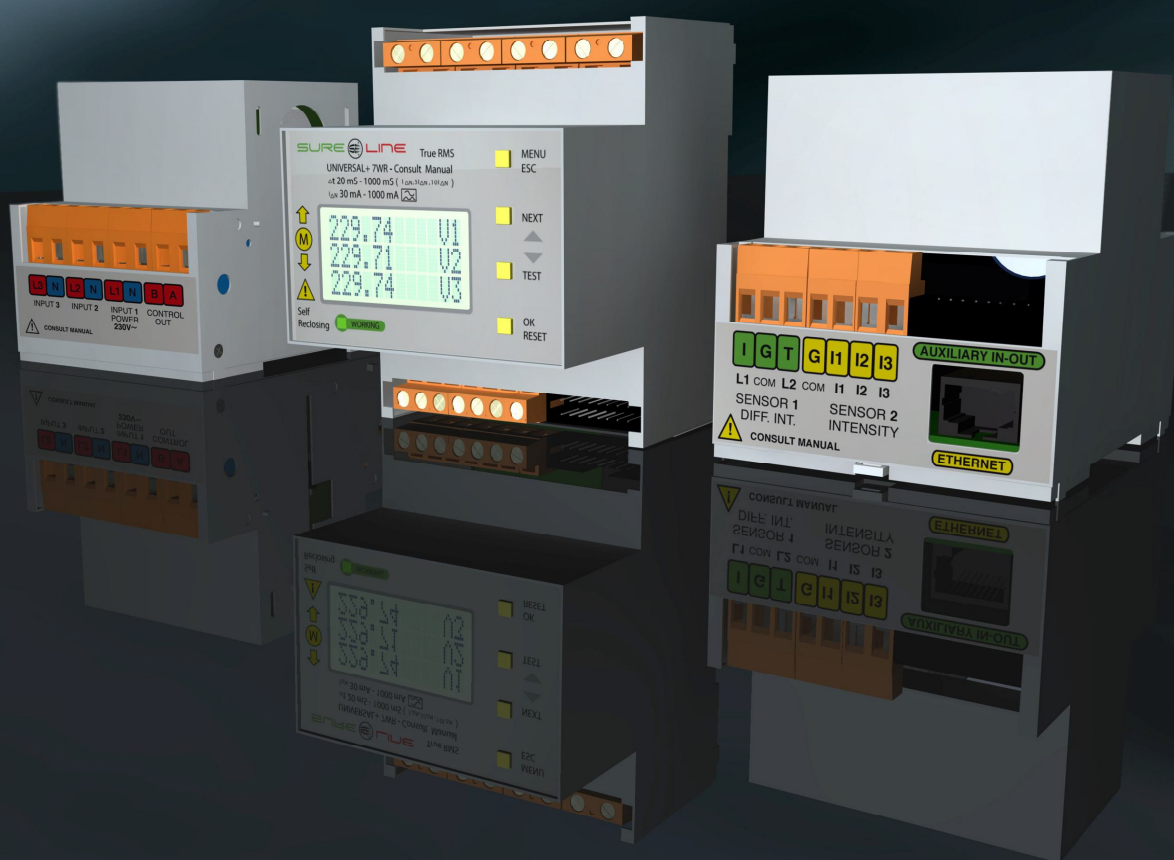

Consult appended manuals for specific models:

[Generic UNIVERSAL+ 7WR M1, M2 and M3 manual](#)

[Manual Safeline Web Service](#)

[Instruction manual - DatawatchPro software](#)

[Instruction manual - UNIVERSAL+ 7WR IN OUT](#)

[Instruction manual - UNIVERSAL+ 7WR accessories](#)

Command configuration (protection device upon power supply cut-off):

M1 = Command 1 (Command built-in reclosure motor-drive for MCB from 6 to 63A, 2 and 4-pole, Icu up to 15kA)

M2 = Command 2 (Command external reclosure motor-drive, for external MCB)

Moulded case from 80 to 250A, 4-pole (Icu up to 100kA)

MCB from 10 to 125A, 2 and 4-pole (Icu up to 50kA)

MCB from 6 to 63A, 2 and 4-pole (Icu up to 15kA)

M3 = Command 3 (External reclosure relay/contactors command from 25 to 1250A, 2 and 4-pole)

M5 = Command 5 (Tripping of SHUNT TRIP DEVICE for external MCB, manual reclosure 2 and 4-pole)

Intensity depends on external MCB

INDEX

Chapter 1 – Introduction

1.1 Nomenclature	5
------------------------	---

Chapter 2 – User's guide (front panel and display)

2.1 Functions of the keys	6
2.2 User PIN	7
2.3 Start-up sequence	7
2.4 Main display screens	7
2.5 Display menu	8
2.5.1 Shutdown of unit	8
2.5.2 Tests	9
2.5.3 Auto-manual, automatic sequential reclosures	9
2.5.4 Alarm configuration	9
2.5.5 Most recent cut-off	11
2.5.6 Most recent alarm	11
2.5.7 Mean RMS display	11
2.5.8 Alarm disconnect counters	11
2.5.9 Maximum measurements	12
2.5.10 Minimum measurements	12
2.5.11 Deletion of counters and registers	12
2.5.12 Automatic sequential reclosures	12
2.5.13 Connection delay	13
2.5.14 I measurement transformer ratio	13
2.5.15 I/O external module 1	13
2.5.16 I/O external module 2	13
2.5.17 Relay manual control	13
2.5.18 Unlocking and reset of reclosures (manually)	13
2.5.19 Remote input 1	13
2.5.20 Remote input 2	13
2.5.21 Temperature and humidity probe	14
2.5.22 TCP/IP configuration	14
2.5.23 Language	15
2.5.24 Changing user PIN	15
2.5.25 Clock	15
2.5.26 Time programmer	15
2.5.27 Total reset and default configuration ex-factory	16
2.5.28 Screenlight	16
2.5.29 Acoustic warnings	16
2.5.30 Version	16
2.5.31 Calibration	16
2.6 Informative messages	16
2.7 Impedance measurement	17
2.8 Alarm delays	17
2.9 Power measurements and power factor in the harmonics module	17
2.10 Energy log with built-in 3-year memory	18
2.11 Oscilloscope event-logger in waveform with pre-trigger	18
2.12 Clarification LOG	18
2.13 Explanation differential intensity harmonics measurement	18

Chapter 3 – Technical characteristics

3.1 Technical characteristics - UNIVERSAL+ 7WR M1 Differential, type A	19
3.2 Synoptic tables of characteristics, UNIVERSAL+ 7WR M1, M2 and M3	23
3.3 Description of connection terminals	27
3.4 Description of display panel	27
3.5 Default alarm values ex-factory - UNIVERSAL+ 7WR M1 Version: voltage scale 500E and 1000E	28
3.6 Alarms which cut off the MCB/circuit-breaker of the UNIVERSAL+ 7WR M1 module	29
3.7 Default alarm status (enabled/disabled) ex-factory - UNIVERSAL+ 7WR M1	30
3.8 Alarms with programmable enablement/disablement of output relays (via one or more alarms)	30
3.9 Default automatic reclosure values ex-factory	21

Chapter 4 – User's/installation guide

4.1 Precautions/warnings for the user/installer	32
4.2 Transport and handling	33
4.3 Installation	33
4.4 Wiring	33

Chapter 5 – Diagnoses and trouble-shooting

5.1 Diagnosis and solution	33
----------------------------------	----

Chapter 6 – Verification and start-up

6.1 Start-up	34
6.2 "Real incremental" differential intensity test ($I_{\Delta n}$)	34
6.3 Differential test with rated threshold.....	34
6.4 Differential intensity test - $I_{\Delta n}$ (differential tester).....	34
6.5 External WD (Watchdog) test	35
6.6 MCB (circuit-breaker) test.....	35
6.7 Real incremental autotest of differential protection	35
6.8 Autotest of differential.....	35
6.9 Diagnosis of cut-off	35
6.10 Redundant cut-off devices	35

Chapter 7 – Description of protections

7.1 Differential protection.....	36
7.2 Protection against permanent and transient overvoltage (Progressive performance curve Voltage/ Time).....	36
7.3 Adaptation to Standard EN 50550:2011	36
7.4 Protection against permanent and transient low voltage	36
7.5 Protection against MCB tripping	36

Chapter 8 – Additional options

8.1 Protection against intense transient overvoltages of very short duration (nS y μS).....	37
--	----

Chapter 9 – Cut-off. Tripping times.

9.1 Total cut-off time of the MCB	37
---	----

Chapter 10 – Usage

10 Usage.....	37
---------------	----

Chapter 11 – Description of basic components

11.1 Differential intensity toroidal transformers TRDF18 and TRDF26.....	37
11.2 Intensity toroidal transformers TRIT14 and TRIT18.....	38
11.3 Ancillary MCB switch 2 and 4-pole Schupa (Gewiss Group).....	38
11.4 Cut-off device (tripping coil) Schupa (Gewiss Group).....	38
11.5 Ancillary MCB switch 2 and 4-pole G.E.....	38
11.6 Cut-off device (tripping coil) G.E.	38

Chapter 12 – Technical service

12.1 Technical service.....	38
-----------------------------	----

Chapter 13 – Maintenance

13.1 Maintenance	38
------------------------	----

Chapter 14 – Guarantee

14.1 Guarantee card.....	39
--------------------------	----

Chapter 15 – Wiring diagrams

15.1 Wiring diagrams.....	40
---------------------------	----

Chapter 16 – Modbus TCP/IP communication protocol , Port 502

16.1 Modbus TCP/IP communication protocol, Port 502.....	48
--	----

Chapter 17 – TCP/IP. HTTP communication protocol. WebServer.

17.1 TCP/IP. HTTP communication protocol. WebServer.....	56
--	----

Important: Depending on the versions of the software and of the UNIVERSAL+ 7WR model and (consult these on the identifying label on the side of the unit and on its display and/or WebServer), different protections/alarms, measurements, connections and characteristics are included. These are to be found in the corresponding manuals and synoptic tables.

Chapter 1 – Introduction

1.1 Nomenclature - UNIVERSAL+ 7WR M1 Differential, type A:

7WR [**M1**] [] [] [] [] [] [] [] [] [] [] [] [] [] [] [] [] [] [] []

1 2 3 4 5 6 7 8 9 10 11 12 13 14 15 16 17

1- Command configuration (protection device for cut-off from mains)

[**M1**] = Command 1 (Built-in reclosure motor-drive command for MCB from 6 to 63A, 2 and 4-pole) , 0 - 70A

[**M1 SR**] = M1 + Automatic data dispatch to a remote server via Internet: Specially designed to work with "SafeLine Web Service" administration software.

2 - Phases

[**T**] = Three-phase 4-pole

[**M**] = Single-phase 2-pole

3 – Differential intensity sensitivity

[**A10-300mA**] = $I_{\Delta n}$ 10-300mA. Timed differential type A.

Delay if value $>35\text{mA}$ (Δt) from 80ms to 1000ms ($I_{\Delta n}$, 2 $I_{\Delta n}$, 5 $I_{\Delta n}$, 10 $I_{\Delta n}$). Delay if value $\leq 35\text{mA}$ (Δt) 40ms ($I_{\Delta n}$), 10ms 5 $I_{\Delta n}$ (instantaneous)

[**A30-1000mA**] = $I_{\Delta n}$ 30-1000mA. Timed differential type A.

Delay if value $>35\text{mA}$ (Δt) from 80ms to 1000ms ($I_{\Delta n}$, 2 $I_{\Delta n}$, 5 $I_{\Delta n}$, 10 $I_{\Delta n}$). Delay if value $\leq 35\text{mA}$ (Δt) 40ms ($I_{\Delta n}$), 10ms 5 $I_{\Delta n}$ (instantaneous)

[**A100-3000mA**] = $I_{\Delta n}$ 100-3000mA. Timed differential type A.

Delay (Δt) from 100ms to 3000ms ($I_{\Delta n}$, 2 $I_{\Delta n}$, 5 $I_{\Delta n}$, 10 $I_{\Delta n}$)

[**N**] = No measurement-differential intensity protection (do not select suffix in box 9 and 14)

4 – Version: Voltage measuring scale (line neutral) AC

[**250E**] = full measuring scale line neutral 250V Pk

[**500E**] = full measuring scale line neutral 500V Pk

[**1000E**] = full measuring scale line neutral 1000V Pk

5 – Power supply-measurement frequency

[**50Hz**] = 50Hz (standard)

[**60Hz**] = 60Hz

6 – Supply voltage

[**115V**] = 115V AC (Line Neutral)

[**230V**] = 230V AC (Line Neutral) (standard)

7 – Version: Energy log with 3-year memory

[] No suffix = without energy log and without built-in 3-year memory

[**G**] = with energy log and without built-in 3-year memory

8 – Version: oscilloscope event-logger in waveform with pre-trigger, voltage and intensity channels (built-in 600-event memory)

[] No suffix = without oscilloscope event-logger in waveform with pre-trigger, voltage and intensity channels (built-in 600-event memory)

[**W**] = with oscilloscope event-logger in waveform with pre-trigger, voltage and intensity channels (built-in 600-event memory)

9 – Version: oscilloscope event-logger in waveform with pre-trigger, differential intensity channel (built-in 600-event memory)

[] No suffix = without oscilloscope event-logger in waveform with pre-trigger, differential intensity channel (built-in 600-event memory)

[**D**] = with oscilloscope event-logger in waveform with pre-trigger, differential intensity channel (built-in 600-event memory)

10 – Version: basic precision - voltage and intensity

[**HP0.2**] = 0,2% precision in voltage and intensity

[**HP0.4**] = 0,4% precision in voltage and intensity

11 – Version: display

[] No suffix = Display with backlighting

[**NZ**] = Display without backlighting

12 – Power supply (Line Neutral)

[] No suffix = Not designed to allow reconnection of the new digital counters

[**CT**] = Designed to allow reconnection of the new digital counters

13 – Line intensity measurement toroidal transformer AC (single-phase: 1 pc; three-phase: 3 pcs)

[**TRIT14**] = TRIT14 (internal \varnothing 14 mm)

[**TRIT18**] = TRIT18 (internal \varnothing 18 mm)

14 – Differential intensity measurement toroidal transformer AC (single-phase and three-phase: 1 pc)

[**TRDF18**] = TRDF18 (internal \varnothing 18 mm)

[**TRDF26**] = TRDF26 (internal \varnothing 26 mm)

15 – Ancillary MCB intensity

[] = 6A, 10A, 16A, 20A, 25A, 32A, 40A, 50A, 63A

16 – Ancillary MCB tripping curve

[] = C, B, D, K (C : standard)

17 – Ancillary MCB breaking capacity, in accordance with IEC 60947-2.

[] = 10kA, 15kA (10kA : standard)

Example: UNIVERSAL+ 7WR M1 T A30-1000mA 500E 50Hz 230V G W D HP0.4 TRIT14 TRDF18 40A C 10kA

Attention: Please, refer to the identifying label on the side of the unit.

Chapter 2 – User's guide (front panel and display)

2.1 Functions of the keys

The contextual keys permit the user to surf the menu and follow on-screen, cursor and flashing figure indications. These intuitive, user-friendly keys have different logical value depending on the context.

MENU / ESC:

Outside the menu:

- enters menu mode

Within the menu:

- returns to previous level or quits menu mode
- in process of modification of values (flashing), quits without modifying data

NEXT / (up):

Outside the menu:

- following measurement screen

Within the menu:

- goes to next level
- increases a flashing value
- goes to next screen

TEST / (down):

Outside the menu:

- returns to previous measurement screen
- held down for more than one second, runs differential intensity test

Within the menu:

- Goes down one level
- decreases a flashing value
- goes to previous screen

RESET / OK:

Outside the menu:

- unit is reinitiated in the event of locking or during a counting process
- general reset (see section below)

Within the menu:

- enters submenus and confirms changes
-

GENERAL RESET

Outside the menu and held down for more than 10 seconds, the unit undergoes a GENERAL RESET.

Very important:

The general reset of the unit is a total deletion of the recorded data, alarms detected and recorded and status of the unit, with the exception of:

- Manual shutdown of the unit
- Shutdown of the unit by time programmer
- Total accrued cut-off counter
- Alarm configurations
- User PIN
- Logged event counters

The general reset causes the ancillary MCB to cut off (OFF) and its subsequent switch-on (ON) provided that the unit is not in a state of manual shutdown or by time programmer and that there is no alarm to impede such action.

2.2 User PIN

The user PIN represents a high degree of security for the owner since this is the sole means whereby the programmed parameters can be validated. Any changes in programmed values only come into effect once said PIN has been entered.

Made up of 4 digits, each one from 0 to 9

- Default PIN enabled at factory: **1,2,3,4**
- The user PIN can be changed if one is in possession of the current one
- The PIN is one and the same for surfing Internet

WARNING: For security reasons, no master code exists. In case of loss, the user must contact the manufacturer to have the unit re-programmed and thoroughly verified. It is recommended that this PIN be noted down and kept in a safe place.

2.3 Start-up sequence

1. Upon energy being supplied to the unit, the loading process of the condensers of the two main cut-off circuits commences. The screen indicates the progress of verification and monitoring of the state of this operation before the recloses (duration from 0V \cong 20 secs).
2. Should the unit be without energy, off or locked, it would resume where it left off, in this informative screen
3. Should a connection delay be programmed, its corresponding informative screen appears indicating time left till reclosure.
4. Start-up test: automatically carries out a verification of the internal electronic system, of the differential intensity toroidal core and the differential alarm (approx. 3-10 secs.).
5. Immediately previous to the MCB reclosing, an on-screen warning appears along with acoustic signals which are repeated three times

2.4 Main display screens (please, refer to synoptical tables of characteristics)

There are **45** main screens. To change screen, press "NEXT" to scroll up or "TEST" to scroll down.

The order of the screens is as follows:

Nomenclature

1. RMS voltage measurements	V1, V2 and V3
2. Pk voltage measurements	VPk1, VPk2 and VPk3
3. V crest factor measurements	CFV1, CFV2 and CFV3
4. Composite voltage measurements	V12, V23, V31
5. Voltage unbalance measurements	%DesV1, %DesV2 and %DesV3
6. RMS intensity measurements	A1, A2 and A3
7. Pk intensity measurements	APk1, APk2 and APk3
8. I crest factor measurements	CFI1, CFI2 and CFI3
9. Line impedance measurements	Z1, Z2 and Z3
10. Differential intensity and neutral intensity measurements	mA RMS, mAPk An
11. I unbalance measurements	%DesI1, %DesI2 and %DesI3
12. RMS line 1 measurements	V1, A1, and ID
13. RMS line 2 measurements	V2, A2, and ID
14. RMS line 3 measurements	V3, A3, and ID
15. Voltage frequency measurements	Hz1, Hz2 and Hz3
16. Voltage THD measurements	%ThdV1, %ThdV2 and %ThdV3
17. Intensity THD measurements	%ThdI1, %ThdI2 and %ThdI3
18. Active power measurements	W1, W2 and W3
19. Requested power measurements	W1+, W2+ and W3+
20. Returned power measurements	W1-, W2- and W3-
21. Power factor measurements	PF1, PF2 and PF3
22. Volt-Amper measurements	VA1, VA2 and VA3
23. Reactive inductive power measurements	rL1, rL2 and rL3
24. Reactive capacitive power measurements	rC1, rC2 and rC3
25. Summation of active powers	ΣW
summations of requested powers	$\Sigma W+$
summations of returned powers	$\Sigma W-$
26. Summations of Volt-Amper,	ΣVA
summations of reactive inductive powers	ΣrL
summations of reactive capacitive powers	ΣrC
27. Active energy counter line 1	KWh L1
28. Active energy counter line 2	KWh L2
29. Active energy counter line 3	KWh L3
30. Reactive energy counter line 1	KQh L1
31. Reactive energy counter line 2	KQh L2
32. Reactive energy counter line 3	KQh L3
33. Summations of active energy counters	KWh L123 Active
34. Summations of reactive energy counters	KQh L123 Reactive
35. Status of relays A and B	
36. Status of relays 1, 2, 3 and 4 of module 1	
37. Status of relays 1, 2, 3 and 4 of module 2	
38. Status of inputs 1, 2, 3 and 4 of module 1	
39. Status of inputs 1, 2, 3 and 4 of module 2	
40. Status of timers 1 and 2 of module 1	
41. Status of timers 3 and 4 of module 1	
42. Status of timers 1 and 2 of module 2	
43. Status of timers 3 and 4 of module 2	
44. Temperature and relative humidity measurements	$^{\circ}C$ and %RH
45. Day of the week, date and time	Day, dd/mm/yy, HH:MM:SS
46.	

NOTE: The parameters displayed in inverted commas “-”, indicate that the parameter and, therefore, its corresponding alarm are not implemented in this specific and, consequently, no operation is contemplated

NOTE: The temperature and humidity in inverted commas “-” indicate that the temperature/humidity probe is either not enabled in the menu or that it has not been installed.

NOTE: The logical status of the input/output modules displayed in inverted commas “-”, indicates that the I/O modules are either not enabled in the menu or that they have not been installed.

2.5 Display menu

To enter the menu, click “menu” in any main screen. Once inside the menu, the user can select a submenu by moving the main cursor up or down. To enter this menu, press “OK”. The “ESC” (escape) key permits the user to quit the submenu or menu. In order to confirm the modification of a flashing value, press “OK”.

NOTE: To save all changes in memory, press “ESC” until all submenus and the menu have been quitted. When “ESC” is pressed this last time, the unit asks whether one wishes to save the changes and requests the PIN. If the current PIN is not entered, the changes will not be saved. By defect, certain menus, such as deletion of registers or ex-factory configurations, request the PIN immediately.

NOTE: If more than 3 minutes elapse without any key having been pressed, the auto-quit from menu is activated. This means that the unit automatically quits the menu mode and returns to the last screen displayed.

NOTE: Should an alarm occur whilst surfing the menu, the auto-quit from menu is activated and the alarm is displayed.

All the unit’s option configurations are to be found in the menu’s submenus

The order of the submenus is as follows:

- Shutdown of unit
- Tests
- Auto–manual, Sequential reclosures
- Alarms. Configuration
- Most recent cut-off
- Most recent alarm
- RMS visualisation mean
- Alarm disconnect counters
- Maximum measurements
- Minimum measurements
- Delete counters/measurements
- Sequential reclosures
- Connection delay
- I measurement transformer ratio
- I/O external module 1
- I/O external module 2
- Manual control relays
- Unlocking and reset de reclosures
- Remote input 1
- Remote input 2
- Temperature and humidity probe
- TCP/IP configuration
- Language
- Change user PIN
- Clock
- Time programmer
- General reset and default ex-factory configuration
- Screen light
- Beep (acoustic warning)
- Version
- Calibration

2.5.1 Shutdown of unit

Permits the user to order the voluntary shutdown of the ancillary MCB. When “OK” is pressed, two options are given:

- OFF with PIN. Warning: only recloses with PIN
- OFF without PIN

The first option permits shutdown of the unit. Start-up can only be done by entering the PIN.

The second option permits shutdown of the unit. Start-up does not require the PIN.

When “OK” is pressed in either of these two options, the units advises, both by an acoustic signal and on-screen, of the cut-off of the MCB and indicates “Motor OFF”. Subsequently, it remains on warning standby and displays the following text:

Option 1: “OFF, unit OFF. Press reset key to enter PIN and reset”.

Option 2: “OFF, unit OFF. Press reset key to reset”.

2.5.2 Tests (please, refer to synoptical tables of characteristics)

Real incremental protection test. This test verifies the programmed alarms and provides the real cut-off value,

The following tests can be run:

→	ID (differential intensity)	Real incremental protection test.
	MCB	MCB cut-off test
	External WD (external Watchdog)	WD cut-off test

The real incremental test injects a voltage or a *real, incremental value* sinusoidal intensity which is added onto the existent line measurement. This produces an alarm/cut-off due to the alarm threshold having been exceeded.

2.5.3 Auto-manual, automatic sequential reclosures

By sequential reclosure, one is to understand any reclosure subsequent to a disconnection caused by an alarm which disappears when the MCB is disconnected. In the present case, following the alarm, the unit enters the different cycles of sequential reclosures programmed for the different alarms since it cannot be known whether or not the alarm has disappeared until such time as the unit recloses again and the parameter can be measured.

Each alarm has its own table of sequential reclosures indicating:

- Foreseen number of reclosure attempts
- Interval between attempts

With a parameter which is common to all denominated "Number of reclosures reset to zero time".

If the alarm were permanent, every time the unit reclosed it would disconnect again, thus entering an infinite cycle. In order to avoid this, the automatic sequential reclosures table limits the number to one that the user/installer deems prudent/advisable.

When "OK" is pressed in this submenu, the following configurable option is displayed:

→	<input checked="" type="checkbox"/> Automatic	default, ex-factory
	<input type="checkbox"/> Manual	

Option 1: Runs the automatic sequential reclosures sequence table corresponding to the alarm.

Option 2: This locks the unit and makes human intervention mandatory. The user can press "reset" to unlock and reset manually.

This submenu makes it easier for the user to transfer from automatic or manual mode without the need to edit the automatic reclosure tables again

NOTE: Another way to avoid generating sequential reclosures is to set the number of reclosures in one or various tables to "0" value.

2.5.4 Alarm configuration (please, refer to synoptical tables of characteristics)

When "OK" is pressed in "Alarms", a submenu group is displayed from which the alarm to be programmed can be selected.

The configurable parameters for each alarm, both RMS and Pk, are the alarm value and the time delay. An alarm occurs when the measurement value is equal or superior to the programmed value and remaining so during a time delay equal or superior to that programmed.

The submenus are:

→	OFF MCB enabled by alarm	
	RMS overvoltage	
	Pk overvoltage	
	RMS low voltage	
	RMS differential intensity	(See NOTE 1 below)
	Pk differential intensity	(See NOTE 2 below)
	RMS intensity	
	Pk intensity	
	Voltage unbalance	
	Intensity unbalance	
	Neutral intensity	
	Over-temperature	(OFF value must be > ON value)
	Low temperature	(OFF value must be < ON value)
	Over-humidity	
	Low humidity	
	Voltage THD	
	Intensity THD	
	Over-frequency	
	Low frequency	
	Power factor	
	Phase sequence	

Submenu OFF MCB enabled by alarm

The alarms which can be *programmed to cut off or not* the ancillary MCB, selectable and accessible on pressing "OK" in this submenu, are the following:

- Intensity
- Neutral intensity
- Power factor
- Voltage THD
- Intensity THD
- Voltage unbalance
- Intensity unbalance
- Power 1 (W)
- Power 2 (W)
- Over-temperature
- Low temperature
- Over-humidity
- Low humidity
- Over-frequency
- Low frequency
- Phase sequence
- Remote input 1
- Remote input 2
- Time programmer

Submenus which indicate the name of the alarm. They permit the alarm delay and value to be configured.

RMS overvoltage
 Pk overvoltage
 RMS low voltage
 RMS differential intensity (See NOTE 1 below)
 Pk differential intensity (See NOTE 2 below)
 RMS intensity
 Pk intensity
 Voltage unbalance
 Intensity unbalance
 Neutral intensity
 Over-temperature (OFF value must be > ON value)
 Low temperature (OFF value must be < ON value)
 Over-humidity
 Low humidity
 THD voltage
 Intensity THD
 Over-frequency
 Low frequency
 Power factor
 Phase sequence

Value: The value can be V, A, mA, %, °C, RH, Hz, etc.

Delay: The delay can be RMS delay, Pk delay or delay in seconds.

The delays for the RMS alarms are **RMS delays** and, for the Pk alarms, **Pk delays**.

RMS delay = the frequency period. 1 cycle = 20ms (50Hz)
 Pk delay = wave sampling speed. 1 sample = 156.25us (50Hz)

Common to the following submenus is that their time delay is programmed in RMS or Pk delays:

- RMS overvoltage
- Pk overvoltage
- RMS low voltage
- RMS differential intensity (see NOTE 1 below)
- Pk differential intensity (see NOTE 2 below)
- RMS intensity
- Pk intensity

Differential intensity alarm. Differential intensity protection, RMS and Pk, example version IΔn 30-1000mA:

NOTE 1: RMS differential intensity, delay value is directly conditioned by the value of the alarm.

For values ≤ 35mA delay range set at 2 cycles (40ms). Delay RMS: 1 cycle = 20ms (50Hz)

For values > 35mA delay range from 4 to 50 cycles (80ms to 1000ms). Delay RMS: 1 cycle = 20ms (50Hz)

NOTE 2: the value of the Pk differential intensity alarm is automatically recalculated when it is modified and the value of the RMS value is saved as:

$$P \text{ alarm value} = \sqrt{2} \times \text{RMS alarm value.}$$

The value of the Pk delay is directly conditioned by the value of the Pk alarm. Pk delay: 1 sample = 156,25us (50Hz)

For values ≤ 50mA Pk delay range from 7 to 45 samples (1,09ms to 7,03ms). Permanently enabled alarm.

For values > 50mA Pk delay range from 7 to 58 samples (1,09ms to 9,06ms). Permanently disabled alarm.

NOTE 3: Exception: when the value of the RMS differential intensity alarm IΔn ≤ 35mA:

In this case, the Pk differential alarm is permanently auto-enabled and the Pk delay can only be programmed in a range of 7 to 45 samples (1,09ms to 7,03ms).

RMS differential intensity alarm: Cannot be disabled in its configuration menu

Pk differential intensity alarm if the RMS value ≤ 35mA: permanently enabled. Cannot be disabled in its configuration menu.

Pk differential intensity alarm if the RMS value > 35mA: permanently disabled. Cannot be enabled in its configuration menu.

Common to the following submenus is that their time delay is programmed in seconds:

- Voltage unbalance
- Intensity unbalance
- Neutral intensity
- Over-temperature
- Low temperature
- Over-humidity
- Low humidity
- Voltage THD
- Intensity THD
- Over-frequency
- Low frequency
- Power factor
- Phase sequence

2.5.5 Most recent cut-off

Displays the most recent known protection (alarm which *provoked* a cut-off). When "OK" is pressed, a second screen comes up indicating the date and time of said cut-off.

2.5.6 Most recent alarm

Displays the most recent known alarm (alarm which *did not provoke* a cut-off). When "OK" is pressed, a second screen comes up indicating the date and time of said cut-off.

2.5.7 Mean RMS display

Number of measurement means for on-screen display

When "OK" is pressed in this submenu, the following configurable option is displayed:

- | | | | | |
|---|-------------------------------------|-------|------------------------|---------------------|
| → | <input type="checkbox"/> | 100ms | (Mean RMS - 5 cycles) | |
| | <input type="checkbox"/> | 200ms | (Mean RMS - 10 cycles) | |
| | <input type="checkbox"/> | 300ms | (Mean RMS - 15 cycles) | |
| | <input type="checkbox"/> | 400ms | (Mean RMS - 20 cycles) | |
| | <input checked="" type="checkbox"/> | 500ms | (Mean RMS - 25 cycles) | default, ex-factory |

NOTE: The mean measurements are: RMS voltage, RMS intensity, RMS differential intensity, composite voltages V12, V23 and V31, neutral intensity, W, W+, W-, VA, VARC, VARL powers and power factor.

2.5.8 Alarm disconnect counters (please, refer to synoptical tables of characteristics)

This submenu permits the user to consult which and how many alarms have occurred.

When "OK" is pressed in this submenu, all the alarm counters are displayed in diverse screens.

When "NEXT" or "TEST" (up or down) is pressed, either the following screen or the previous one is displayed. To quit the menu, press "ESC". Should one wish to delete the counters, press "OK" in any of the screens. They can also be deleted from the menu "delete counters and events".

These counters are:

overvoltage counters.
 low voltage counters
 intensity counters
 differential intensity counter
 neutral intensity counter
 voltage unbalance counters
 intensity unbalance counters
 voltage THD counters
 intensity THD counters
 over-temperature counter
 low temperature counter
 over-humidity counter
 low humidity counter
 over-frequency counters
 low frequency counters
 power factor counters
 phase sequence counter
 MCB counter
 time programmer counter
 remote input 1 counter
 remote input 2 counter
 lock counter
 power OFF counter
 total counter
 accrued total counter (undeletable)

Nomenclature

ST L1 =, ST L2 = y ST L3 = 65535
 IT L1 =, IT L2 = and IT L3 = 65535
 I L1 =, I L2 = and I L3 = 65535
 ID = 65535
 In = 65535
 DesV1 =, DesV2 = and DesV3 = 65535
 DesI1 =, DesI2 = and DesI3 = 65535
 THDV1 =, THDV2 = and THDV3 = 65535
 THDI1 =, THDI2 = and THDI3 = 65535
 STemp. = 65535
 ITemp. = 65535
 SRH. = 65535
 IRH. = 65535
 SHzV1 =, SHzV2 = and SHzV3 = 65535
 IHzV1 =, IHzV2 = and IHzV3 = 65535
 PF L1 =, PF L2 = and PF L3 = 65535
 SPhase = 65535
 MCB = 65535
 PROG.H. = 65535
 Reln1 = 65535
 Reln2 = 65535
 Lock = 65535
 Power = 65535
 Total = 65535
 T.acum = 65535

2.5.9 Maximum measurements (please, refer to synoptical tables of characteristics)

This submenu permits the user to consult the maximum measurements. Only the measurement of highest value is memorised. When "OK" is pressed in this submenu, all the registers of maximum measurements are displayed in diverse screens. When "NEXT" or "TEST" (up or down) is pressed, either the following screen or the previous one is displayed. To quit the menu, press "ESC". Should one wish to initialise the registers, press "OK" in any of the screens. They can also be initialised from the menu "delete counters and events". These values are not memorised when power is removed from unit.

Maximum measurement: voltage L1, L2 and L3
 Maximum measurement: voltage unbalance L1, L2 and L3
 Maximum measurement: intensity L1, L2 and L3
 Maximum measurement: differential intensity
 Maximum measurement: neutral intensity
 Maximum measurement: intensity unbalance L1, L2 and L3
 Maximum measurement: frequency V1, V2 and V3
 Maximum measurement: voltage THD L1, L2 and L3
 Maximum measurement: intensity THD L1, L2 and L3
 Maximum measurement: active power L1, L2 and L3 (Maximeter programmable from 10 secs. to 15 mins.)
 Maximum measurement: apparent power L1, L2 and L3
 Maximum measurement: reactive inductive power L1, L2 and L3
 Maximum measurement: reactive capacitive power L1, L2 and L3
 Maximum measurement: temperature
 Maximum measurement: humidity

2.5.10 Minimum measurements (please, refer to synoptical tables of characteristics)

This submenu permits the user to consult the minimum measurements. Only the measurement of lowest value is memorised. When "OK" is pressed in this submenu, all the registers of minimum measurements are displayed in diverse screens. When "NEXT" or "TEST" (up or down) is pressed, either the following screen or the previous one is displayed. To quit the menu, press "ESC". Should one wish to initialise the registers, press "OK" in any of the screens. They can also be initialised from the menu "delete counters and events". These values are not memorised when power is removed from unit.

Minimum measurement: voltage L1, L2 and L3
 Minimum measurement: frequency V1, V2 and V3
 Minimum measurement: temperature
 Minimum measurement: humidity

2.5.11 Deletion of counters and registers

This submenu permits the user to reset all the counters to zero and to initialise all the unit's registers of maximum and minimum measurements.

When "OK" is pressed in this submenu, four further submenus are displayed:

Energy:	Resets the energy counters of all the main screens to zero.
Alarms :	Resets the cut-alarm counters to zero
Maximum measurements:	Initialises the maximum measurement registers
Minimum measurements:	Initialises the minimum measurement registers

Using "NEXT" or "TEST" (up or down), situate the cursor on the submenu which one wishes to reset to zero or initialise. Then, press "OK".

2.5.12 Automatic sequential reclosures

This submenu permits the user to configure the sequential reclosure tables and the reset to zero time of the number of automatic sequential reclosures.

When "OK" is pressed in this submenu, five further submenus are displayed::

- I. Differential
- I.
- I. neutral, THDI, DESI, PF, Power 1 and 2
- MCB
- Reset to zero time of reclosures

As their name indicates, the first four permit the user to configure the reclosure number table and the cycle time between reclosures corresponding to each group of alarms.

The last permits the user to configure the reclosure number counter's reset to zero time in all the tables once the unit has reclosed successfully

If, between reclosure cycles, the unit resets and no longer detects the problem which originated the action, then the "Number of reclosures reset to zero time" or "Automatic self-start of reclosures" countdown begins. When the reset to zero time has elapsed, the reclosure number counters reset to zero. In this way, we are starting again from zero and the next time an anomaly occurs, the unit will once again dispose of the total number of automatic sequential reclosures.

NOTE: A way to avoid generating sequential reclosures is to set the number of reclosures in one or various tables to "0" value. This locks the unit and makes human intervention mandatory. The user can press "reset" to unlock and reset manually. On the other hand, should one wish to do this as a general rule, then goes to the "Auto-Manual, sequential reclosures" menu and configure in manual mode..

NOTE: During the course of a reclosure cycle or when the unit is locked due to the number of automatic sequential reclosures having been used up, the user can terminate this condition by pressing "reset". This action unlocks the unit and resets the reclosures. Likewise, via Internet, using the option "unlocking and reset of reclosures" on WEB page "UNIT CONFIGURATION"

2.5.13 Connection delay

This submenu permits the user to configure diverse connection delays.

When "OK" is pressed, the following submenus are displayed:

- Power failure
Voltage cut-off, frequency, voltage THD, voltage unbalance

Delaying the connection subsequent to a power failure (from 0 to 999s) can be useful in those installations having more than one unit. By distributing the line load among small, consecutive reclosures, one avoids a peak current in the main junction box which could otherwise cause the general MCB to trip. It can likewise be used subsequent to an alarm due to voltage, frequency, harmonic distortion of the voltage or voltage unbalance.

It can also be interesting to delay connection in the case of there being specialised equipment requiring an idle time subsequent to a cut-off. By doing so, short-time disconnections-connections would be avoided

2.5.14 I measurement transformer ratio

This submenu permits the user to program the ratio of the convolutions of the intensity measurement transformers for lines L1, L2 and L3.. Programmable from 50A / 5A, up to 10,000A / 5A (in5A steps).

IMPORTANT: For the UNIVERSAL+ 7WR M1 Differential, type A program only value 70 A / 5 A.

Three-phase:

7WR M1 Differential, type A	70A	Programming:	70 A / 5 A	Only toroidals TRIT14, TRIT18
-----------------------------	-----	--------------	------------	-------------------------------

Single-phase:

7WR M1 Differential, type A	70A	Programming:	70 A / 5 A	Only toroidals TRIT14, TRIT18
-----------------------------	-----	--------------	------------	-------------------------------

2.5.15-16 I/O external module 1 and I/O external module 2

These two submenus permit the I/O modules to be enabled

Example of module 1 (module 2 is the same)

When "OK" is pressed in Yes/No, the following configurable option is displayed:

- Yes
- No default, ex-factory

2.5.17 Relay manual control

This submenu permits relays A and B and relays R1,R2, R3 and R4 of the external modules 1 and 2 to be enabled manually. When "OK" is pressed, display indicates:

- Relay A
- Relay B
- Relay 1 M1
- Relay 2 M1
- Relay 3 M1
- Relay 4 M1
- Relay 1 M2
- Relay 2 M2
- Relay 3 M2
- Relay 4 M2

2.5.18 Unlocking and reset of reclosures (manually)

Unlocking of the unit in the event of its having been locked and/or reset to zero of the cycle counters of all the sequential reclosures tables. Disabling of the relays enabled by locking.

2.5.19-20 Remote input 1 and Remote input 2 (I/O external modules)

This submenu indicates to the unit the type of input signal which is to be connected to the remote control inputs. The unit is able to detect both normal and rocking input signals.

NORMAL:

A normal signal is one which has only two states. OFF(0) and ON(1). It is similar to a switch.

When OFF(0), remote control is disabled
When ON(1), remote control is enabled (Alarm)

ROCKING:

A rocking signal is one which goes from OFF(0) to ON(1) and then back to OFF(0). It is similar to a pushbutton.

At each to-and-fro signal, the unit goes from one state to the other. This means that if the remote control is disabled, on detecting a to-and-fro change in the signal, it becomes enabled. It remains in this state (alarm) until it detects another to-and-fro change in the input signal.

It can also be configured so that, upon the remote control being enabled, an automatic locking and reset of reclosures is generated.

When "OK" is pressed, two submenus are displayed:

- Type
- Action

When "OK" is pressed in "Type", the following configurable option is displayed:

- Normal default, ex-factory
- Rocking

When "OK" is pressed in "Action", the following configurable option is displayed:

- Unlocking and reset of reclosures

NOTE: One can also configure it so that the unit shuts down when the remote control is enabled.

Please, refer to submenu "OFF MCB by:" in "Alarms" submenu

2.5.21 Temperature and humidity probe

This submenu indicates to the unit that a temperature and relative humidity measuring probe is connected.

When "OK" is pressed, the following configurable option is displayed:

- Yes
- No default, ex-factory

NOTE The temperature and humidity measurements in inverted commas "-" indicate that the temperature/humidity probe is either not enabled in the menu or that it has not been installed. Consult the accessories, I/O relay modules, temperature and humidity probe manual

2.5.22 TCP/IP configuration

This submenu permits the user to see the unit's TCP/IP configuration, see the Lan LED, configure the default ex-factory parameters and **enable/disable the security protection which prevents the possibility of the unit's parameters being modified via Internet (WebServer in display and read-only mode).**

When "OK" is pressed, the following submenus are displayed:

- Information TCP/IP
- LED Lan
- Default configuration ex-factory
- Disable Tcp/Ip programming?

When "OK" is pressed in "TCP/IP information", the following information is displayed (the parameters indicate are those ex-factory by default):

- Port = 80 (clicking OK in this parameter, its value can be changed)
- IP = 192.168.2.10 (clicking OK in this parameter, its value can be changed)
- Gateway = 192.168.2.1 (clicking OK in this parameter, its value can be changed)
- Mask = 255.255.255.000
- MAC = xx.xx.xx.xx.xx.xx

When "OK" is pressed in "LED Lan", "LED = Lan" is displayed on-screen. The green LED on the front panel acts as LED Lan. Press "ESC" to quit.

Press "OK" in "Default configuration" if you wish to restore the TCP/IP parameters to ex-factory values.

Press "OK" in "Disable Tcp/Ip programming?" if you wish to prevent the possibility of the unit's parameters being modified via Internet (WebServer in read-only mode).

NOTE: For security reasons, if the Tcp/Ip programming is disabled via Internet, it can only be enabled from the unit itself.

2.5.23 Language

This submenu permits the user to change from Spanish to English or vice versa.

When "OK" is pressed in "Language", the following configurable option is displayed:

→ Spanish default, ex-factory
 English

2.5.24 Changing user PIN

The user PIN represents a high degree of security for the owner since this is the sole means whereby the programmed parameters can be validated. Any changes in programmed values only come into effect once said PIN has been entered.

Made up of 4 digits, each one from 0 to 9

- Default PIN enabled at factory: **1,2,3,4**
- The user PIN can be changed if one is in possession of the current one
- The PIN is one and the same for surfing Internet

NOTE: The 0,0,0,0 PIN is a special PIN which totally cancels request for same. The unit will not request it in any change in programming. The user can change any value either via the front panel or Internet (on condition that the latter is not in read-only mode). This PIN can be useful as a temporary measure during a training process or an overhaul or revision of the unit. However, its use is not recommended on a permanent basis in an installation due to problems which could be caused by unauthorised personnel.

WARNING: **For security reasons, no master PIN exists. In case of loss, the user must contact the manufacturer to have the unit re-programmed and thoroughly verified. It is recommended that this PIN be noted down and kept in a safe place.**

2.5.25 Clock

This submenu permits the user to configure the day of the week, date and time.

When "OK" is pressed in "Clock", the current day of the week, date (dd/mm/yy) and time (HH:MM:SS) are displayed. Pressing "OK" and entering programming mode, one can modify the day of the week, date or time

Using "NEXT" or "TEST" (up or down), select the day of the week, date and/or time and press "OK". The value to be modified flashes indicating that this value can be changed. Press "OK" to validate.

The chronological register of the most recent alarm and most recent cut-off sets the date in these registers.

2.5.26 Time programmer

These submenus permit the user to enable the time programmer and configure it.

With the time programmer one can program the enablement/disablement of the relays of the external I/O modules and/or the ancillary MCB (circuit-breaker).

Each day of the week has 6 programs, allowing 6 different time frames to be established wherein any relay of the external I/O modules or the ancillary MCB can be enabled.

Programming is in HH:MM (hours:minutes) enablement and HH:MM disablement, plus an independent box per program in order to indicate which of these 6 possible daily programmes are enabled. All programmes whose box is not enabled/selected will be ignored.

IMPORTANT: If the time programmer is not associated to any relay or MCB, when a program runs out, nothing will happen. In order to associate the relays to the time programmer, please refer "Relay alarms" on the Web page.

When "OK" is pressed ", the following submenus are displayed:

→ Yes/No
Monday Every day
Tuesday Saturdays and Sundays
Wednesday Monday to Friday
Thursday
Friday
Saturday
Sunday

When "OK" is pressed in Yes/No, the following configurable option is displayed:

→ Yes Time programmer enabled (default, ex-factory)
 No Time programmer disabled. All programmes are ignored.

When "OK" is pressed in a day of the week, the enabled/disabled state of the 6 daily programmes which have been selected (disabled ex-factory, by default):

→ P1 (disabled ex-factory, by default)
 P2 (disabled ex-factory, by default)
 P3 (disabled ex-factory, by default)
 P4 (disabled ex-factory, by default)
 P5 (disabled ex-factory, by default)
 P6 (disabled ex-factory, by default)

Using "NEXT" or "TEST" (up or down), one situates oneself in the program one wishes to configure.

When "OK" is pressed in one of the 6 programmes, one enters a configuration submenu where 3 configurable options are displayed:

- Px Enabled/disabled, individually for each programme
 00:00h ON Enable/ON - for example, a relay and/or the MCB
 00:00h OFF Disable/OFF - for example, a relay and/or the MCB

The 1st option indicates whether that specific program is active or not

The 2nd option permits the hour and minutes of ON to be configured

The 3rd option permits the hour and minutes of OFF to be configured

2.5.27 Total reset and default configuration ex-factory

This submenu restores the whole unit to its original ex-factory settings. All existent data is deleted, viz: information on unit status, alarms/cut-off counters (except accumulated total), event-logging counters, energy counters, maximum and minimum values, log, input/output status, manual control relays, unit configuration, relay alarms, relay timers, schedule programmer, harmonics, event-logger, kWh-kQh history, manual switch-off, relay-enabling alarms, reclosure cycles, locking due to reclosure conclusion, status of all relays, status of remote inputs, all editable names (except the unit's itself), intensity transformer ratio, reclosures, etc.

Exception: Section "Access configuration". The TCP/IP configuration, IS NOT restored to its default ex-factory values. Neither are they restored in the total accumulated alarms/cut-off counter, the user PIN and the unit's editable name.

ATTENTION: Before executing this operation, the unit will cut OFF preventively. Once the unit has reset, it will automatically switch ON. The user / installer must carry out anew the programming of the alarms and others if these differ from the default configuration ex-factory.

2.5.28 Screen light

This submenu permits the screen illumination mode to be selected. The default ex-factory mode is the timed one. When 30 seconds has elapsed after any key having been pressed, the screen light goes off. As long as keys are being pressed, the light remains on. The permanent mode keeps the light on all the time except for when a reclosure is imminent. When this is the case, the light goes off and, once the internal load values of the capacitors have been restored, it comes back on

- Timed default, ex-factory
 Permanent

2.5.29 Acoustic warnings (beep)

This submenu permits the acoustic warnings to be enabled/disabled.

- Enabled default, ex-factory
 Disabled

2.5.30 Version

This submenu permits the user to see the unit's software model and version..

Warning: A change of the software version means a variation in the unit's characteristics. These should be consulted in the manual for the specific version

2.5.31 Calibration Solely at factory

2.6 Informative messages

The unit informs at all times what is happening both on the front screen panel and by accessing Internet

1. Upon start-up of the unit, when power is supplied for the first time or after one or various connections/disconnections, the following message may be displayed:

"Loading..."

along with a bar indicating the energy level of the internal capacitors

Just previous to reclosure, depending on the model, if the unit has differential intensity protection, it carries out a verification test of this protection.

"Test ID"

Once the test has finished, the message "Test OK" is displayed.

Three acoustic warnings with the messages:

Screen: "Warning reclosure I-ON"

WEB: "Reclosing..."

indicate the imminent reclosure of the ancillary MCB

Now, the unit is reclosed.

Screen: "I-ON"

WEB: "MCB-ON (reclosed)"

2. If the user shuts down the unit manually, one of the following messages is displayed:

Screen: "OFF, Unit shut down. Press reset to enter PIN and reclose manually"

"OFF, Unit shut down. Press reset to reclose manually"

"OFF from Internet. Manual shutdown by user (ON protected by PIN)"

WEB: "OFF from unit. Manual shutdown by user (ON protected by PIN)"
 "OFF from unit. Manual shutdown by user (ON not protected by PIN)"
 "OFF from Internet. Manual shutdown by user (ON protected by PIN)"

Or if shut down via the time programmer:

"OFF ordered by time programmer"

3. In the event of an alarm, the corresponding descriptive message and value are displayed on-screen during a short time. Moreover, this message can be consulted in the "most recent cut-off" and/or "most recent alarm" menus where the date and time are also included.

4. If there is an alarm which, in order to reclose again, uses the sequential reclosure tables, its corresponding reclosure cycle and time message is displayed.

"Reclosure cycle in progress R(x)"
 "Alarm name" + "Time to next reclosure. Press RESET"
 "10m:00s"

5. If, however, the unit becomes locked, due to either the reclosure cycles having been used up or to the reclosures being programmed in manual mode, the following message is displayed:

Screen: "Alarm name" + "UNIT LOCKED due to finalisation of reclosures. Press rest for manual reclosure."
 "Alarm name" + "UNIT LOCKED. Reclosures in manual mode. Press rest for manual reclosure."

WEB: "UNIT LOCKED due to finalisation of reclosures. Unlock in "UNIT CONFIGURATION"
 "UNIT LOCKED. Reclosures in manual mode. Unlock in "UNIT CONFIGURATION"

6. Other messages corresponding to connection delays are displayed when these are programmed to a value other than zero:

"Delay power failure, in progress. T =XXXs"
 "Delay voltage, frequency, voltage THD, DesV, in progress. T =XXXs"

Lastly, the following **error messages** may be displayed:

7. If there is a power supply below limits:

"Failure, Vac energy OFF"
 "Low VAC"

8. While a test (differential intensity) is being run and the expected alarm is not detected; The message "Test error" is displayed along with a long, intermittent beep. There is an anomaly in the unit and it must be revised immediately. Do NOT use the unit. Consult the technical service.

9. When the unit indicates the existence of a *non-existent*, due to a communication or supply lead having been disconnected, etc.

"Communication error, external module 1 not found"
 "Communication error, external module 2 not found"
 "Communication error, module Temp/RH not found"
 "Communication error, I2C clock not found"

10. Anomaly in verification of RAM memory: "Error RAM"

2.7 Impedance measurement

Impedance measurement (Z) on the unit's screen and WebServer,

When consumption is zero ($I = 0$) . impedance is infinite ($Z = \infty$).

Since the character screen does not have the infinity symbol (∞), this is shown as "0.00". Therefore, when consumption is zero, impedance is infinite and is expressed as $Z = 0.00$. The same applies for measurements displayed via WebServer.

La impedance is calculated using the formula V_{rms} / I_{rms} . Therefore, the value of Z is in ohms (resistance)

2.8 Alarm delays

NOTE: The delays of the RMS alarms can vary additionally between 0 and 15ms depending on moment RMS is calculated

The delays of the peak alarms can vary additionally between 0 and 312uS due to conversion and calculation

The delays of the programming alarms can vary +/-1 second

2.9 Power measurements and power factor in the harmonics module

Solely in precision versions HP0.2 and HP0.4

When making calculations in the harmonics module, one must bear in mind that the power and power factor measurements are merely a guidance. This is due to the fact that, in order to achieve a high resolution and precision in the RMS measurements, the analogue-digital converter has to work with oversampling, thus generating a filtering of the native wave. This factor, therefore, has a negative effect on the accuracy of said power and power factor measurements in the harmonics module. The higher the chosen harmonics index, the more significant this will be. This effect does not occur in the lower precision versions (those without the "HP" suffix).

2.10 Energy log with built-in 3-year memory

Memory: The unit has sufficient memory to store three years' monthly, daily, hourly and 5-minute frame consumptions. Once the 3-year memory is used up, no more data can be stored.

In order to store another 3-year cycle, the memory must be deleted after having entered the user pin.

Iniciar memoria de consumos energéticos

Aviso: Se perderán todos los datos guardados en memoria.

PIN Guardar

Attention: Update the time and date in the unit's clock in order to obtain correct data in the energy log manually or automatically.

2.11 Oscilloscope event-logger in waveform with pre-trigger. (V – I / Differential I.)

NOTE: When an event occurs, the waveforms are recorded in a non-volatile memory.

The recording time for a V – I event (3-phase, 6-channel x 1024 resolution) takes between 620 ms and 720 ms (time to access non-volatile memory). The recording time for a differential I. event I. (1-channel x 6144 resolution) takes between 620 ms and 720 ms (time to access non-volatile memory).

Streamed events of a different type of trigger will all be recorded only if there is an interval of ≥ 720 ms between each and the next.

Repetitive events (of the same type of trigger) will be recorded every 10 secs (time alarm indicated)

Memories: the unit has two memories to store 600 V – I events and 600 differential intensity events. Once either 600-event memory is used up, no used up, no more data can be stored.

Should one wish to store another 600-event cycle, the memory must be deleted after having entered the user PIN.

Iniciar memoria del registrador de eventos, voltaje e intensidad

Aviso: Se perderán todos los datos guardados en memoria.

PIN Guardar

Iniciar memoria del registrador de eventos, intensidad diferencial

Aviso: Se perderán todos los datos guardados en memoria.

PIN Guardar

Attention: Update the time and date in the unit's clock in order to obtain correct data in the event logger manually or automatically.

2.12 Clarification LOG

In the event of simultaneous alarms, only the first detected is logged.

In the event of various alarms going off in less than 1 second, only the first detected is logged.

2.13 Explanation differential intensity harmonics measurement

A low pass filter is included for the measurement of the differential intensity. Thus, the filter and the type of differential transformer have a bearing on the precision in the measurement of harmonics. Consequently, the measurement of harmonics is merely a guide.

Chapter 3 – Technical characteristics (please, refer to synoptical tables of characteristics 3.2)

3.1- Technical characteristics - UNIVERSAL+ 7WR M1 Differential, type A

Technical characteristics - UNIVERSAL+ 7WR M1 Differential, type A			
(power: L-N 230V AC ± 15% 50Hz sinusoidal alternating)		Single-phase 2-pole (M) only L1 / Three-phase 4-pole (T) L1, L2, L3	
Measurement: True RMS voltage L1, L2, L3 (line neutral)	from 50,00V to 350,00V (version: 500E = full scale 500V Pk) from 100,00V to 700,00V (version: 1000E = full scale 1000V Pk)		
Measurement: Peak voltage L1, L2, L3 (line neutral)	from 70,00V to 500,00Vpk (version: 500E = full scale 500V Pk) from 140,00V to 1000,00Vpk (version: 1000E = full scale 1000V Pk)		
Measurement: True RMS voltage between phases L1 L2, L2 L3, L3 L1	from 100,00V to 500,00V (version: 500E = full scale 500V Pk) from 200,00V to 1000,00V (version: 1000E = full scale 1000V Pk)		
Measurement: AC voltage L1, L2, L3 (line neutral)	from 50,00V to 350,00V (version: 500E = full scale 500V Pk) from 100,00V to 700,00V (version: 1000E = full scale 1000V Pk)		
Measurement: DC voltage L1, L2, L3 (line neutral)	from 0,00V to 450,00V (version: 500E = full scale 500V Pk) from 0,00V to 900,00V (version: 1000E = full scale 1000V Pk)		
Measurement: True RMS intensity and AC intensity	from 0,05A to 70,00A		
Measurement: Peak intensity and DC intensity	from 0,07A to 98,99Apk		
Measurement: Neutral intensity	from 0,50A to 70,00A		
Measurement: Differential intensity, Version –Sensitivity: IΔn 10-300 mA	RMS differential I. from 1,6mA to 300,0mA Pk differential I. from 2,3mA to 424,3mA	AC differential I. DC differential I.	from 1,6mA to 300,0mA from 0,0mA to 424,3mA
Measurement: Differential intensity, Version –Sensitivity: IΔn 30-1000 mA	RMS differential I. from 5mA to 1000,0mA Pk differential I. from 7,1mA to 1414,2mA	AC differential I. DC differential I.	from 5mA to 1000,0mA from 0,0mA to 1414,2mA
Measurement: Differential intensity, Version –Sensitivity: IΔn 100-3000 mA	RMS differential I. from 15mA to 3000,0mA Pk differential I. from 21,2mA to 4242,7mA	AC differential I. DC differential I.	from 15mA to 3000,0mA from 0,0mA to 4242,7mA
Measurement: Active power (W) L1, L2, L3, ΣL123	Resolution: 0,1W		
Measurement: Apparent power (VA) L1, L2, L3, ΣL123	Resolution: 0,1VA		
Measurement: Reactive inductive power L1, L2, L3, ΣL123	Resolution: 0,1VarL (from an FP of 0.997)		
Measurement: Reactive capacitive power L1, L2, L3, ΣL123	Resolution: 0,1VarC (from an FP of 0.997)		
Measurement: Requested power L1, L2, L3, ΣL123	Resolution: 0,1 +W		
Measurement: Returned power L1, L2, L3, ΣL123	Resolution: 0,1 -W		
Measurement: Power factor L1, L2, L3	from 0,000 a 1,000		
Measurement: Active power W L1, L2, L3.	Maximeter (power integration) programmable from 10 secs to 15 mins		
DC power (Wdc) de L1, L2, L3 and AC power (Wac) de L1, L2, L3	Resolution: 0,1VA (Depending on external intensity transformer)		
Counter: Active imported energy L1, L2, L3, ΣL123	from 0000000,00001 kWh to 9999999,99999 kWh		
Counter: Active exported energy L1, L2, L3, ΣL123	from 0000000,00001 kWh to 9999999,99999 kWh		
Counter: Reactive energy L1, L2, L3, ΣL123	from 0000000,00001 kQh to 9999999,99999 kQh (from an FP of 0.997)		
Measurement: Voltage unbalance L1, L2, L3 (line neutral)	%		
Measurement: Intensity unbalance L1, L2, L3	%		
Measurement: Voltage crest factor L1, L2, L3 (line neutral)			
Measurement: Intensity crest factor L1, L2, L3			
Measurement: Line impedance L1, L2, L3 (line neutral)	Z		
Measurement: line frequency L1, L2, L3 (line neutral)	45,0Hz to 55,0Hz		
Measurement: Temperature	from -40,0 °C to +100,0 °C		
Measurement: Humidity	from 0,0% to 100,0% RH		
Measurement: Total Harmonic Distortion (THD 63 harmonics) 50Hz	from 0,1 to 999,9% % Measurement precision : 1%		
In voltage L1, L2 and L3 (line neutral). In intensity L1, L2 and L3	1 year ± (% measurement precision + 2 digits + 0.05% of F.E.) 22°C ± 5 °C, 30 a 75% HR		
% Measurement precision in: RMS voltage L1, L2, L3 (line neutral)	0.2 %	Version HP 0.2	0.4 % Version HP 0.4
% Measurement precision in: DC (Vdc) voltage L1, L2, L3 (line neutral)	0.2 %	Version HP 0.2	0.4 % Version HP 0.4
% Measurement precision in: AC (Vac) voltage L1, L2, L3 (line neutral)	0.2 %	Version HP 0.2	0.4 % Version HP 0.4
% Measurement precision in: RMS intensity L1, L2, L3	0.2 %	Version HP 0.2	0.4 % Version HP 0.4
% Measurement precision in: DC (Idc) intensity L1, L2, L3	0.2 %	Version HP 0.2	0.4 % Version HP 0.4
% Measurement precision in: AC (Iac) intensity L1, L2, L3	0.2 %	Version HP 0.2	0.4 % Version HP 0.4
% Measurement precision in: differential intensity RMS, AC, DC	1.0 %	Version HP 0.2	1.0% Version HP 0.4
% Measurement precision in: Active power (W)	% Precision: V+I (RMS)+0.1		
% Measurement precision in: Apparent power (VA)	% Precision: V+I (RMS)+0.1		
% Measurement precision in: Reactive power	% Precision: V+I (RMS)+1		
% Measurement precision in: DC (Wdc) power	% Precision: V+I (RMS)+0.1		
% Measurement precision in: AC (Wac) power	% Precision: V+I (RMS)+0.1		
Specifications of typical precision and conditions for the module at:	1 year ± (% measurement precision + 2 digits + 0.2% of F.E.) with 22°C ± 5 °C, humidity 30 to 75% HR, range: 10-90%, 50Hz sinusoidal		
Alarms programmable in value and delay			
ΔV Pk (voltage difference) L1, L2, L3 (line neutral)	from 20V to 200V	Delay: 156,25 μs	
ΔV RMS (voltage difference) L1, L2, L3 (line neutral)	from 1V to 300V	Delay: 20ms	
RMS overvoltage L1, L2, L3 (line neutral)	from 245V to 276V	Delay: from 20ms to 5000ms (version F.E. 500V Pk)	
RMS overvoltage L1, L2, L3 (line neutral)	from 245V to 276V	Delay: from 20ms to 5000ms (version F.E. 1000V Pk)	
Pk overvoltage L1, L2, L3 (line neutral)	from 350Vpk to 450Vpk	Delay: from 0,156ms to 9,06ms (version F.E. 500V Pk)	
Pk overvoltage L1, L2, L3 (line neutral)	from 350Vpk to 450Vpk	Delay: from 0,156ms to 9,06ms (version F.E. 1000V Pk)	
RMS low voltage L1, L2, L3 (line neutral)	from 180V to 210V	Delay: from 20ms to 10000ms (version F.E. 500V Pk)	
RMS low voltage L1, L2, L3 (line neutral)	from 180V to 210V	Delay: from 20ms to 10000ms (version F.E. 1000V Pk)	
RMS overvoltage L1, L2, L3 (line neutral)	Set at >300V ± 5%	Delay: 1000ms	
RMS overvoltage L1, L2, L3 (line neutral)	Set at >350V ± 5%	Delay: 260ms	
RMS overvoltage L1, L2, L3 (line neutral) only version F.E. 1000V Pk	Set at >400V ± 5%	Delay: 80ms	
RMS intensity L1, L2, L3	from 1A to 63A	Delay: from 20ms to 10000ms	
Pk intensity L1, L2, L3	from 2APk to 89Pk	Delay: from 0,46ms to 9,06ms	
Neutral intensity	from 1A to 63A	Delay: from 2S to 180S	
Power 1 W L1, L2, L3	from 1 to 9999999 W	Delay: from 1S to 999S	
Power 2 W (Maximeter-integration programmable from 10 secs to 15 mins.)	from 1 to 9999999 W	L1, L2, L3	
Power factor L1, L2, L3	from 0,99 to 0,01	Delay: from 1S to 180S	
Voltage THD L1, L2, L3. As from harmonic 2–63, programmable by harmonic and harmonics bracket	from 1% to 90%	Delay: from 2S to 180S	
Intensity THD L1, L2, L3. As from harmonic 2–63, programmable by harmonic and harmonics bracket	from 1% to 90%	Delay: from 2S to 180S	
Over-frequency L1, L2, L3 (line neutral)	from 51Hz to 55Hz	Delay: from 1S to 180S	
Low frequency L1, L2, L3 (line neutral)	from 45Hz to 49Hz	Delay: from 1S to 180S	
Phase sequence	-	Delay: from 1S to 180S	
Phase failure			
Voltage unbalance L1, L2, L3 (line neutral)	from 5% to 100%	Delay: from 1S to 180S	
Intensity unbalance L1, L2, L3	from 5% to 100%	Delay: from 1S to 180S	
Over-temperature	de -40,0 °C to +100,0 °C	Delay: from 1S to 180S	
Low temperature	de -40,0 °C to +100,0 °C	Delay: from 1S to 180S	
Over- humidity	from 10% to 90%	Delay: from 1S to 180S	
Low humidity	from 10% to 90%	Delay: from 1S to 180S	
Protection by MCB, 2 or 4-pole	Value, depending on ancillary MCB		
Preventive cut-off due to AC power failure	Yes (by means of built-in reclosure motor-drive and tripping coil)		

Oscilloscope event-logger in waveform with pre-trigger and autoscale V – 1 channel, 6 channels V1, V2, V3, I1, I2, I3, with captures for each event (optional) Six modes of log length in 6 channels. 160ms, 320ms and 640ms (pre-trigger 40ms, 80ms and 160ms) and 20s, 40s y 80s (pre-trigger 5s, 10s and 20s) 600-event storage in built-in memory. Display via WebServer and DataWatchPro.		
Trigger for alarms which can be enabled and are programmable in value and delay. Chronological record for each type of alarm. Display via WebServer with horizontal zoom functions. Multi-channel measurement, value and time cursor, 3 mathematical V*I channels, etc. Display via DataWatchPro with offset functions, amplitude, time base, horizontal shift zoom, value and time cursor,		
Alarm: ΔV Pk (voltage difference) L1, L2, L3		
Alarm: ΔV RMS (voltage difference) L1, L2, L3		
Alarm: RMS overvoltage L1, L2, L3		
Alarm: Pk overvoltage L1, L2, L3		
Alarm: RMS intensity L1, L2, L3		
Alarm: Pk intensity L1, L2, L3		
Alarm: Voltage THD L1, L2, L3		
Alarm: Intensity THD L1, L2, L3		
Alarm: Over-frequency L1, L2, L3		
Alarm: Low frequency L1, L2, L3		
Remote input 1 and Remote input 2 (digital inputs). External trigger		
Sampling 6 channels, log length 160ms pre-trigger 40ms	6,4KHz per channel. Native resolution (1024 points in 160ms)	
Sampling 6 channels, log length 320ms pre-trigger 80ms	6,4KHz per channel. Resolution /2 (1024 points in 320ms)	
Sampling 6 channels, log length 640ms pre-trigger 160ms	6,4KHz per channel. Resolution /4 (1024 points in 640ms)	
Sampling 6 channels, log length 20,48s pre-trigger 5,12s	Native resolution (1024 RMS samples, 20ms in 20s)	
Sampling 6 channels, log length 40,96s pre-trigger 10,24s	Resolution /2 (1024 RMS samples, 20ms in 40s)	
Sampling 6 channels, log length 81,92s pre-trigger 20,48s	Resolución /4 (1024 RMS samples, 20ms in 80s)	
Other		
Independent sequential reclosures, programmable in number and time:		
Differential intensity	from 0 to 30 reclosures	from 00m:00s to 99m:59s
Intensity	from 0 to 10 reclosures	from 03m:00s to 99m:59s
Ancillary MCB	from 0 to 10 reclosures	from 03m:00s to 99m:59s
Neutral I and/or power factor and/or THDI and/or I unbal. and/or power1 and/or power2	from 0 to 10 reclosures	from 03m:00s to 99m:59s
Real incremental test of protections: Differential intensity $I_{\Delta n}$	Yes, value of cut-off (differential tester)	
Ancillary MCB tripping test	Yes	
Real incremental autotest of protections: Differential	Yes, prior to reclosure of ancillary MCB	
Autotest: Differential Version ($I_{\Delta n}$ 10-300 mA)	Yes, every 1 second if $I_{\Delta n} < 3,3mA$	
Autotest: Differential Version ($I_{\Delta n}$ 30-1000 mA)	Yes, every 1 second if $I_{\Delta n} < 10mA$	
Autotest: Differential Version ($I_{\Delta n}$ 100-3000 mA)	Yes, every 1 second if $I_{\Delta n} < 30mA$	
Cut-off time (2-pole MCB)	2-5ms typical (cf.: "Cut-off. Tripping times")	
Cut-off time (2-pole MCB) version with "L" suffix	5-10ms typical (cf.: "Cut-off. Tripping times")	
Non-response time upon power failure	Upon total 230V AC power failure, three-phase 4-pole version: 500 ms	
Non-response time upon power failure	Upon total 230V AC power failure, single-phase 2-pole version: 500 ms	
Mechanical endurance: Sureline reclosure module	100.000 complete manoeuvres (ON OFF)	
Mechanical endurance: 2-pole General Electric MCB	20.000 complete manoeuvres (ON OFF)	
Mechanical endurance: 4-pole General Electric MCB	15.000 complete manoeuvres (ON OFF)	
Programmable, independent start-up delays	Upon mains power failure and protection of voltage, frequency, THDV, voltage unbalance	
Delay remote inputs 1 and 2	5 ms	
Programmable acoustic warnings	Enabled or disabled	
Chronological logger of most recent alarm and most recent cut-off	with value and year, month, day, hour and minute.	
Screen with programmable illumination	Timed or permanent	
Remote inputs 1 and 2 programmable: Programmable input signal, normal or rocking.	With programmable unlocking option and reset of reclosures upon enablement.	
Individual alarm counter	cf synoptic tables of characteristics	
Registers maximum and minimum measurements	cf synoptic tables of characteristics	
Alarm central, telecontrol and automation	10 logical outputs (relays) and 10 logical inputs. With individual programmable enablement	
Time programmer with high-precision clock:	6 programs per day, programming in hours and minutes, enablement of 10 logical outputs (relays)	
Working temperature L-N 230V AC $\pm 15\%$	0° to +45° C. Standard version -10° to +55° C. Industrial version :models with "TI" suffix -25° to +70° C. Extended industrial version :models with "TE" suffix	
Full scale (F.E.): Differential intensity	500 mA, version: $I_{\Delta n}$ 10-300 mA	
Full scale (F.E.): Differential intensity	1400 mA, version: $I_{\Delta n}$ 30-1000 mA	
Full scale (F.E.): Differential intensity	4200 mA, version: $I_{\Delta n}$ 100-3000 mA	
Full scale (F.E.): Voltage L1, L2, L3:	500V, version: 500E = full scale 500V Pk	
Full scale (F.E.): between phases L1 L2, L2 L3, L3 L1	900V, version: 500E = full scale 500V Pk	
Full scale (F.E.): Voltage L1, L2, L3:	1000V, version: 1000E = full scale 1000V Pk	
Full scale (F.E.): between phases L1 L2, L2 L3, L3 L1	1800V, version: 1000E = full scale 1000V Pk	
Full scale (F.E.): Intensity L1, L2, L3:	100A, in 70A version	
Full scale (F.E.): Active power L1, L2, L3:	Intensity full scale, by voltage full scale (Max. 9999999,9 W)	
Full scale (F.E.): Apparent power L1, L2, L3:	Intensity full scale, by voltage full scale (Max. 9999999,9 W)	
Full scale (F.E.): Reactive power L1, L2, L3:	Intensity full scale, by voltage full scale (Max. 9999999,9 W)	
Full scale (F.E.): DC and AC power L1, L2, L3:	Intensity full scale, by voltage full scale (Max. 9999999,9 W)	
Full scale (F.E.): Harmonic distortion	999,9 %	
Dimensions complete unit: UNIVERSAL+ 7WR M1 + 2-pole MCB	128 mm (7 modules), height: 81mm, 35mm DIN rail	
Dimensions complete unit: UNIVERSAL+ 7WR M1 + 4-pole MCB	163 mm (9 modules), height: 81mm, 35mm DIN rail	
Weight complete unit: UNIVERSAL+ 7WR M1 + 2-pole MCB	900 grs.	
Weight complete unit: UNIVERSAL+ 7WR M1 + 4-pole MCB	1.170 grs.	
Weight toroidal transformer (TRIT14), (TRIT18 or TRDF18), (TRIT26 or TRDF26)	70, 185, 300 gr.	
Guarantee	3 years	
Configurable languages	Spanish and English	
Manual cut-off	2 options: ON again with or without PIN	
Auto/manual mode	Auto: automatic sequential reclosures enabled. Manual: sequential reclosures disabled.	
In accordance with standards: Version sensitivity $I_{\Delta n}$ 10-300 mA Differential, type A	EN 60947-2 (annexe B):2018, IEC 60947-2 (annexe B), UNE 20-600-77(IEC-278), EN 50550:2011*	
Version sensitivity $I_{\Delta n}$ 30-1000 mA Differential, type A	EN 60947-2 (annexe B):2018, IEC 60947-2 (annexe B), UNE 20-600-77(IEC-278), EN 50550:2011*	
Version sensitivity $I_{\Delta n}$ 100-3000 mA Differential, type A	EN 60947-2 (annexe B):2018, IEC 60947-2 (annexe B), UNE 20-600-77(IEC-278), EN 50550:2011*	
	* Adapt parameters according to standard (cf. "Adaptation to standard EN 50550:2011")	
Precision in accordance with standards	UNE-EN 62053-22:2003 (IEC 62053-22:2003) CLASE 0,5S UNE-EN 62053-23:2003 (IEC 62053-23:2003) CLASE 2	
WebServer (Version: HTML 4.01 Transitional, IPV4, connection RJ45 8 pin 10 BASE-T). Modbus TCP/IP, Port 502, and TCP/IP. HTTP communication protocol. WebServer.		
7-channel oscilloscope with autoscale and 3 mathematical V*I channels. Includes instantaneous value measurement cursor in all channels (display in WebServer)		
7-channel oscilloscope with autoscale and offset control functions, amplitude, time base, delay/advance in degrees, multi-channel measurement cursor, Measurement of RMS, Pk, THD, etc. Sampling 7 channels 6,4KHz per channel (display in DataWatchPro)		
Analysis of harmonics spectrum with autoscale (V1, V2, V3, I1, I2 y I3 with 64 harmonics). Measurements of 64 harmonics (range in % and V-A value). Display with continuous refreshment (every 1,5 secs.). Includes measurement cursor (display via WebServer)		
Analysis of 7-channel harmonics spectrum with autoscale (up to harmonic 63, range in % and RMS value).		
Multi-channel measurement cursor and simultaneous analysis of 1, 2, 3, 4, 5, 6 and 7 channels (display via DataWatchPro).		
DWP (DataWatchPro): Professional software for PC with database and graphic analysis.		

300-register graphic logger, 12 channels (46 measurements) with autoscale and variable refreshment (1-600 secs) with temporary max., min. and avg. measurements	
Current value of 46 measurements and Difference in value between maximum and minimum (Max value – Min value) of 46 measurements	
Temporary maximum value (300 registers, 1-600 Secs.) of 46 measurements	
Temporary minimum value (300 registers, 1-600 Secs.) of 46 measurements	
Temporary average value (300 registers, 1-600 Secs.) of 46 measurements	
Graphic energy log, costs and emissions with built-in 3-year memory (optional). Active and reactive energy consumption log. Includes measurement cursor.	
Graphic bar and line display in WebServer for months, days, hours and 5-minute frames.	

AC/DC measurements	
DC voltage (Vdc) de L1, L2, L3 (line neutral)	Range: from 0,00V to 450,00V (version: 500E = full scale 500V Pk)
DC voltage (Vdc) de L1, L2, L3 (line neutral)	Range: from 0,00V to 900,00V (version: 500E = full scale 1000V Pk)
AC voltage (Vac) de L1, L2, L3 (line neutral)	Range: from 50,00V to 350,00V (version: 500E = full scale 500V Pk)
AC voltage (Vac) de L1, L2, L3 (line neutral)	Range: from 100,00V to 700,00V (version: 1000E = full scale 1000V Pk)
DC intensity (Idc) de L1, L2, L3	Depending on external intensity transformer
AC intensity (Iac) de L1, L2, L3	Depending on external intensity transformer
DC power (Wdc) de L1, L2, L3 and AC power (Wac) de L1, L2, L3	Resolution: 0,1VA (Depending on external intensity transformer)
AC and DC differential intensity measuremet	Depending on external differential intensity transformer

64-harmonic spectrum with distortion, range in % and V-A value, + THD	
THD alarm and measurement as from harmonic 2-63, programmable by harmonic and harmonics bracket	
%HDF (harmonic distortion) voltage L1, L2, L3 from harmonic k0 to 63 (64 harmonics)	64 harmonics, range from 0,1 to 999,9%
%HDF (harmonic distortion) intensity L1, L2, L3 from harmonic k0 to 63 (64 harmonics)	64 harmonics, range from 0,1 a 999,9%
Voltage L1, L2, L3, from harmonic k0 to 63 (64 harmonics)	64 harmonics
Intensity L1, L2, L3, from harmonic k0 to 63 (64 harmonics)	64 harmonics

Differential protection type A		
I _{ΔN} 50Hz alternating sinusoidal (AC)	1 x I _{ΔN} Delay if value ≤35mA (Δt): 40ms (I _{ΔN}), 10ms 5 I _{ΔN} (instant)	
Alternating 50Hz rectified sinusoidal (AC)	1 x I _{ΔN} Delay if value >35mA (Δt): from 80ms to 1000ms (I _{ΔN} , 2 I _{ΔN} , 5 I _{ΔN} , 10 I _{ΔN})	
Preventive cut-off	Upon low voltage, insufficient power and AC power failure	
Version: (I_{ΔN} 10-300 mA) RMS differential intensity: I_{ΔN} RMS	Programmable from 10mA up to 300mA	Delay if value ≤35mA (Δt): 40ms (I _{ΔN} , 2 I _{ΔN} , 5 I _{ΔN} , 10 I _{ΔN}) Delay if value >35mA (Δt): from 80ms to 1000ms (I _{ΔN} , 2 I _{ΔN} , 5 I _{ΔN} , 10 I _{ΔN})
Version: (I_{ΔN} 10-300 mA) Pk differential intensity: I_{ΔN} Pk	Programmable from 14mA up to 423mA	Delay if value ≤50mA (Δt): from 1,09ms to 7,03ms Delay if value >50mA (Δt): from 1,09ms to 9,06ms (Alarm not active)
Version: (I_{ΔN} 30-1000 mA) RMS differential intensity: I_{ΔN} RMS	Programmable from 30mA up to 1000mA	Delay if value ≤35mA (Δt): 40ms (I _{ΔN} , 2 I _{ΔN} , 5 I _{ΔN} , 10 I _{ΔN}) Delay if value >35mA (Δt): from 80ms to 1000ms (I _{ΔN} , 2 I _{ΔN} , 5 I _{ΔN} , 10 I _{ΔN})
Version: (I_{ΔN} 30-1000 mA) Pk differential intensity: I_{ΔN} Pk	Programmable from 42mA up to 1414mA	Delay if value ≤50mA (Δt): from 1,09ms to 7,03ms Delay if value >50mA (Δt): from 1,09ms to 9,06ms (Alarm not active)
Version: (I_{ΔN} 100-3000 mA) RMS differential intensity: I_{ΔN} RMS	Programmable from 100mA up to 3000mA	Delay (Δt): from 80ms to 3000ms (I _{ΔN} , 2 I _{ΔN} , 5 I _{ΔN} , 10 I _{ΔN})
Version: (I_{ΔN} 100-3000 mA) Pk differential intensity: I_{ΔN} Pk	Programmable from 141mA up to 4242mA	Delay (Δt): from 1,09ms to 9,06ms (Alarm not active)

Oscilloscope event-logger in waveform with pre-trigger and autoscale differential intensity channel (optional)	
1 capture channel for each event: ID. 1 record length mode set at 960ms with pre-trigger at 840ms. Storage capacity for 600 events in built-in memory, display via WebServer. Trigger by alarms whose value and delay can be enabled and programmed. Chronological register per type of alarm. display via WebServer with horizontal zoom functions. Value and time measurement cursor.	
Per RMS differential intensity alarm (IDn RMS)	
Per Pk differential intensity alarm (ID Pk)	
Per Remote input 1 (digital input). External trigger	
Per Remote input 2 (digital input). External trigger	
Sampling 1 channel record length 960ms, pre-trigger 840ms	6,4KHz per channel. Native resolution (6144 points in 960ms)

Differential analysis. RMS, Peak, AC and DC measurements. Differential intensity oscilloscope.	
Graphic and numerical display. RMS, Peak, AC and DC measurements. Differential intensity oscilloscope with autoscale and automatic or manual Y axis scale. Includes measurement cursor. Continuously refreshed display (every 1.5 secs.). "Real-time" chart recorder for 300 registers with autoscale and automatic or manual Y axis scale, with temporary maximum, minimum and average measurements. Includes measurement cursor. Continuously refreshed display (every 1.5 secs.).	

Version: L-N 230V AC 50Hz power supply. Version: 1000E = full scale measurement line neutral 1000V Pk	
Consumption: POWER L1-N	1,8W at 230V AC RMS 50Hz alternating sinusoidal
Input voltage: POWER L1-N (normal conditions)	230V AC - 20 % + 30% RMS 50Hz alternating sinusoidal
Input voltage: POWER L1-N (abnormal conditions - maximum limit)	from 300V up to 450V AC RMS 50Hz alternating sinusoidal
Transient input voltage L-N (peak voltage)	1 KV max. (vp) / 300 ms
Input voltage: RMS phase neutral (INPUT 1 L1-N)	up to 450V RMS AC 50Hz
Input voltage: Pk phase neutral (INPUT 1 L1-N)	up to 635V Pk
Input voltage: RMS phase neutral (INPUT 2 L2-N)	up to 450V RMS AC 50Hz
Input voltage: Pk phase neutral (INPUT 2 L2-N)	up to 635V Pk
Input voltage: RMS phase neutral (INPUT 3 L3-N)	up to 450V RMS AC 50Hz
Input voltage: Pk phase neutral (INPUT 3 L3-N)	up to 635V Pk
Input voltage: RMS between phases L1 and L2, L1 and L3, L2 and L3	up to 700V RMS AC 50Hz
Input voltage: Pk between phases L1 and L2, L1 and L3, L2 and L3	up to 990V Pk
Version: L-N 230V AC 50Hz power supply. Version: 500E = full scale measurement line neutral 500V Pk	
Consumption: POWER L1-N	1,8W at 230V AC RMS 50Hz alternating sinusoidal
Input voltage: POWER L1-N (normal conditions)	230V AC - 20 % + 30% RMS 50Hz alternating sinusoidal
Input voltage: POWER L1-N (abnormal conditions - maximum limit)	from 300V up to 450V AC RMS 50Hz alternating sinusoidal
Transient input voltage L-N (peak voltage)	1 KV max. (vp) / 300 ms
Input voltage: RMS phase neutral (INPUT 1 L1-N)	up to 450V RMS AC 50Hz
Input voltage: Pk phase neutral (INPUT 1 L1-N)	up to 635V Pk
Input voltage: RMS phase neutral (INPUT 2 L2-N)	up to 450V RMS AC 50Hz
Input voltage: Pk phase neutral (INPUT 2 L2-N)	up to 635V Pk
Input voltage: RMS phase neutral (INPUT 3 L3-N)	up to 450V RMS AC 50Hz
Input voltage: Pk phase neutral (INPUT 3 L3-N)	up to 635V Pk
Input voltage: RMS between phases L1 and L2, L1 and L3, L2 and L3	up to 500V RMS AC 50Hz
Input voltage: Pk between phases L1 and L2, L1 and L3, L2 and L3	up to 700V Pk

Version: L-N 115V AC 50Hz power supply. Version: 250E = full scale measurement line neutral 250V Pk	
Consumption: POWER L1-N	1,8W at 115V AC RMS 50Hz alternating sinusoidal
Input voltage: POWER L1-N (normal conditions)	115V AC - 20 % + 30% RMS 50Hz alternating sinusoidal
Input voltage: POWER L1-N (abnormal conditions - maximum limit)	from 150V up to 225V AC RMS 50Hz alternating sinusoidal
Transient input voltage L-N (peak voltage)	500 V máx. (vp) / 300 ms
Input voltage: RMS phase neutral (INPUT 1 L1-N)	up to 225V RMS AC 50Hz
Input voltage: Pk phase neutral (INPUT 1 L1-N)	up to 317V Pk
Input voltage: RMS phase neutral (INPUT 2 L2-N)	up to 225V RMS AC 50Hz
Input voltage: Pk phase neutral (INPUT 2 L2-N)	up to 317V Pk
Input voltage: RMS phase neutral (INPUT 3 L3-N)	up to 225V RMS AC 50Hz
Input voltage: Pk phase neutral (INPUT 3 L3-N)	up to 317V Pk
Input voltage: RMS between phases L1 and L2, L1 and L3, L2 and L3	up to 250V RMS AC 50Hz
Input voltage: Pk between phases L1 and L2, L1 and L3, L2 and L3	up to 350V Pk
Version: L-N 115V AC 50Hz power supply. Version: 500E = full scale measurement line neutral 500V Pk	
Consumption: POWER L1-N	1,8W at 115V AC RMS 50Hz alternating sinusoidal
Input voltage: POWER L1-N (normal conditions)	115V AC - 20 % + 30% RMS 50Hz alternating sinusoidal
Input voltage: POWER L1-N (abnormal conditions - maximum limit)	from 150V up to 225V AC RMS 50Hz alternating sinusoidal
Transient input voltage L-N (peak voltage)	500 V máx. (vp) / 300 ms
Input voltage: RMS phase neutral (INPUT 1 L1-N)	up to 225V RMS AC 50Hz
Input voltage: Pk phase neutral (INPUT 1 L1-N)	up to 317V Pk
Input voltage: RMS phase neutral (INPUT 2 L2-N)	up to 225V RMS AC 50Hz
Input voltage: Pk phase neutral (INPUT 2 L2-N)	up to 317V Pk
Input voltage: RMS phase neutral (INPUT 3 L3-N)	up to 225V RMS AC 50Hz
Input voltage: Pk phase neutral (INPUT 3 L3-N)	up to 317V Pk
Input voltage: RMS between phases L1 and L2, L1 and L3, L2 and L3	up to 250V RMS AC 50Hz
Input voltage: Pk between phases L1 and L2, L1 and L3, L2 and L3	up to 350V Pk

Built to allow reconnection of the new digital counters

With the “CT” option, the unit’s power supply goes into a high impedance state after a set time of a power cut. This function allows the new new digital counters to be reconnected subsequent to a cut-off due to over-consumption.

3.2 – Synoptic tables of characteristics, UNIVERSAL+ 7WR M1, M2 and M3

UNIVERSAL+ 7WR (3-year guarantee)	7WR					
	M1		M2		M3	
Command configuration (protection device)	M	T	M	T	M	T
Single-phase 2-pole (M) only L1 / Three-phase 4-pole (T) L1, L2, L3	M	T	M	T	M	T
Oscilloscope event-logger in waveform with pre-trigger and autoscale. 6 channels V1, V2, V3, I1, I2, I3, with captures for each event Option "W"						
Three modes of record length in 6 channels 160ms, 320ms and 640ms (pre-trigger: 40ms, 80ms and 160ms) + three modes of record length in 6 channels 20s, 40s y 80s (pre-trigger 5s, 10s y 20s) 600-event storage in built-in memory. Display via WebServer and DataWatchPro Trigger for alarms which can be enabled and are programmable in value and delay. Chronological record for each type of alarm. Display via WebServer with horizontal zoom functions. Multi-channel measurement, value and time cursor, 3 mathematical V*I channels, etc. Display via DataWatchPro with offset control functions, amplitude, time base, horizontal shift zoom, multi-channel measurement, value and time cursor, etc.						
Alarm: ΔV Pk (voltage difference) L1, L2, L3, set delay (transients and fast micro-cuts)	•	•	•	•	•	•
Alarm: ΔV RMS (voltage difference) L1, L2, L3, set delay (transients and dips)	•	•	•	•	•	•
Alarm: RMS overvoltage L1, L2, L3	•	•	•	•	•	•
Alarm: Pk overvoltage L1, L2, L3	•	•	•	•	•	•
Alarm: RMS intensity L1, L2, L3	•	•	•	•	•	•
Alarm: Pk intensity L1, L2, L3	•	•	•	•	•	•
Alarm: Voltage THD (total harmonic distortion) L1, L2, L3	•	•	•	•	•	•
Alarm: Intensity THD (total harmonic distortion) L1, L2, L3	•	•	•	•	•	•
Alarm: Over-frequency L1, L2, L3 and Alarm: Low frequency L1, L2, L3	•	•	•	•	•	•
Remote input 1 and Remote input 2 (digital inputs). External trigger	•	•	•	•	•	•
Historical logger LOG, connection, disconnection and alarm information log (connection and disconnection log)						
Alarm and disconnection/connection chronological logger. With measurement value and year, month, day, hour and minute.						
RMS overvoltage L1, L2, L3 and Pk overvoltage L1, L2, L3L1, L2, L3	•	•	•	•	•	•
RMS low voltage L1, L2, L3	•	•	•	•	•	•
RMS intensity L1, L2, L3 and Pk intensity L1, L2, L3	•	•	•	•	•	•
RMS differential intensity (IDn RMS) and Pk differential intensity (ID Pk)	•	•	•	•	•	•
Neutral intensity	•	•	•	•	•	•
Power1 W L1, L2, L3	•	•	•	•	•	•
Power2 W L1, L2, L3 (MDI, programmable from 10 secs. to 15 mins.)	•	•	•	•	•	•
Power factor L1, L2, L3	•	•	•	•	•	•
Voltage THD (total harmonic distortion) L1, L2, L3 and Intensity THD (total harmonic distortion) L1, L2, L3	•	•	•	•	•	•
Voltage unbalance L1, L2, L3 and Intensity unbalance L1, L2, L3	•	•	•	•	•	•
Phase sequence	•	•	•	•	•	•
Over-temperature and Low temperature	•	•	•	•	•	•
Over-humidity and Low humidity	•	•	•	•	•	•
Over-frequency L1, L2, L3 and Low frequency L1, L2, L3	•	•	•	•	•	•
Remote input 1 and Remote input 2 (digital inputs)	•	•	•	•	•	•
Time programmer	•	•	•	•	•	•
AC power failure (Power OFF) and Connection AC supply (Power ON)	•	•	•	•	•	•
7-channel oscilloscope with autoscale and offset control functions, amplitude, time base, delay/advance in degrees, multi-channel measurement cursor, Measurement of RMS, Pk, THD, etc. (display in DataWatchPro)						
7-channel oscilloscope with autoscale and automatic or manual Y axis scale and 3 mathematical V*I. channels. Includes instantaneous value measurement cursor in all channels. Continuously refreshed display (every 1.5 secs.). (Display via Webserver)						
Voltage V1, Intensity I1 (Display on WebServer and DataWatchPro)	•	•	•	•	•	•
Voltage V2, Intensity I2 (Display on WebServer and DataWatchPro)	•	•	•	•	•	•
Voltage V3, Intensity I3 (Display on WebServer and DataWatchPro)	•	•	•	•	•	•
Differential intensity ID (Display on WebServer and DataWatchPro)	•	•	•	•	•	•
Analysis of 7-channel harmonics spectrum with autoscale (63 harmonics, range en % and value V - A).						
Multi-channel measurement cursor and simultaneous analysis of 1, 2, 3, 4, 5, 6 and 7 channels. (display in DataWatchPro)						
Analysis: harmonics spectrum with autoscale (V1, V2, V3, I1, I2, I3 and differential I. with 64 harmonics, range in % and value V - A).						
Display with continuous refreshment (every 1.5 secs.). Includes measurement cursor (display on WebServer)						
Voltage V1, Intensity I1 (Display on WebServer and DataWatchPro)	•	•	•	•	•	•
Voltage V2, Intensity I2 (Display on WebServer and DataWatchPro)	•	•	•	•	•	•
Voltage V3, Intensity I3 (Display on WebServer and DataWatchPro)	•	•	•	•	•	•
Differential intensity ID (Display on WebServer and DataWatchPro)	•	•	•	•	•	•
Modbus TCP/IP, Port 502, and TCP/IP. HTTP communication protocol . WebServer.						
Measurements (Reading)	•	•	•	•	•	•
Oscilloscope event-logger counters (Reading)	•	•	•	•	•	•
Alarm counters (Reading) and Energy counters (Reading)	•	•	•	•	•	•
Maximum and minimum measurements (Reading)	•	•	•	•	•	•
Digital outputs (relays) (Reading / Writing of 10outputs) and Digital inputs (Reading of 10 inputs)	•	•	•	•	•	•
Commands: Reset, reset to zero of counters, unlocking of reclosures, etc. (Writing)	•	•	•	•	•	•
Graphic energy log, costs and emissions with (optional) built-in memory. Graphicactive and reactive energy bar and line display in WebServer. Includes measurement cursor. Option "G"						
Energy log (L1 single-phase or ΣL1,2 and 3 three-phase) with built-in 3-year memory						
5-minute interval active and reactive energy consumption log (3-year memory storage)	•	•	•	•	•	•
Hourly active and reactive energy consumption log (3-year memory storage)	•	•	•	•	•	•
Daily interval active and reactive energy consumption log (3-year memory storage)	•	•	•	•	•	•
Monthly interval active and reactive energy consumption log (3-year memory storage)	•	•	•	•	•	•
Oscilloscope event-logger in waveform with pre-trigger and autoscale differential intensity channel Option "D"						
One capture channel for each event: Id. One record length mode set at 960ms with pre-trigger at 840ms. 600-event storage capacity in built-in memory. Display via WebServer. Trigger by alarms whose value and delay can be enabled and programmed. Chronological register by type of alarm. Display via WebServer with horizontal zoom functions, Value and time measurement cursor.						
Alarm: Differential intensity - RMS (IDn RMS)	•	•	•	•	•	•
Alarm: Differential intensity - Pk (ID Pk)	•	•	•	•	•	•
Remote input 1 (digital input). External trigger	•	•	•	•	•	•
Remote input 2 (digital input). External trigger	•	•	•	•	•	•
Multi-interaction between remote units via Internet/Intranet for UNIVERSAL+ 7WR range, M1, M2, M3, M4, MINI M4, 4LOG, 4REM, 6LIR, 6PHAR and 6PHR. They are totally autonomous and, once configured, can communicate remotely with each other via Internet/Intranet to enable or disable their relays A, B, C and D when a programed event occurs.						
WebServer in real time, display with continuous refreshment (every 1.5 secs.) of measurements, max/min measurements, energy counters, alarm counters, input/output status, event log (LOG), unit information and clock – for UNIVERSAL+ 7WR M1, M2, M3, M4 and MINI M4 units						
Alarm central, Tele-control and automation via 10 logical outputs (relays) and 10 logical inputs. For the whole UNIVERSAL+ 7WR M1 range, M2 and M3 units, by means of a range of external modules.						

UNIVERSAL+ 7WR (3-year guarantee)	7WR					
Command configuration (protection device)	M1		M2		M3	
Single-phase 2-pole (M) only L1 / Three-phase 4-pole (T) L1, L2, L3	M	T	M	T	M	T
Differential protection and analysis, type A / B. RMS, Peak, AC and DC measurements. Differential intensity oscilloscope.						
Graphic and numerical display. RMS, Peak, AC and DC measurements Differential intensity oscilloscope with autoscale and automatic or manual Y axis scale. Includes measurement cursor Continuously refreshed display (every 1.5 secs.)	•	•	•	•	•	•
"Real-time" chart recorder for 300 registers with autoscale and automatic or manual Y axis scale, with temporary maximum, minimum and average measurements. Includes measurement cursor. Continuously refreshed display (every 1.5 secs.)	•	•	•	•	•	•
Differential, type A. Alternating sinusoidal and rectified alternating sinusoidal	•	•	•	•	•	•
Differential, type B. Alternating senoidal up to 3kHz, alternating senoidal rectified and direct current DC	•	•				
Built to allow reconnection of the new digital counters	•	•	•	•		
WebServer in real time, display refreshed every 1.5 seconds for variable parameters	•	•	•	•	•	•

300-event graphic logger, 12 channels (46 measurements) with autoscale and variable refreshment (1-600 secs.) with temporary max. min. avg. measurements						
Current value for 46 measurements	•	•	•	•	•	•
Temporary maximum value (300 events, 1-60 secs.) for 46 measurements	•	•	•	•	•	•
Temporary minimum value (300 events, 1-60 secs.) for 46 measurements	•	•	•	•	•	•
Temporary average value (300 events, 1-60 secs.) for 46 measurements	•	•	•	•	•	•
Difference in value between maximum and minimum (Max value – Min value) of 46 measurements	•	•	•	•	•	•
Automatic data dispatch to a remote server via Internet Option "SR"						
By enabling "Remote server TCP/IP configuration", the unit automatically dispatches the data file (Slist.json) to a remote server. This file is dispatched every 5 minutes (in sync with the internal clock)	•	•	•	•	•	•

Measurements						
True RMS and Pk voltage L1, L2, L3	•	•	•	•	•	•
True RMS voltage between phases L1-2, L2-3, L3-1	•	•	•	•	•	•
True RMS and Pk intensity with autoscale L1, L2, L3	•	•	•	•	•	•
Neutral intensity	•	•	•	•	•	•
True RMS and Pk differential intensity with autoscale	•	•	•	•	•	•
Voltage THD (total harmonic distortion) L1, L2, L3 and Intensity THD (total harmonic distortion) L1, L2, L3	•	•	•	•	•	•
Voltage THD L1, L2, L3 of intensity L1, L2, L3 as from harmonic 2 – 63, programmable by harmonic and harmonic range	•	•	•	•	•	•
Voltage unbalance L1, L2, L3	•	•	•	•	•	•
Intensity unbalance L1, L2, L3	•	•	•	•	•	•
Voltage crest factor L1, L2, L3	•	•	•	•	•	•
Intensity crest factor L1, L2, L3	•	•	•	•	•	•
Temperature, relative humidity	•	•	•	•	•	•
Relative temperature and humidity of 6 remote UNIVERSAL+ 7WR TH sensors via Internet/Intranet	•	•	•	•	•	•
Line frequency L1, L2, L3	•	•	•	•	•	•
Line impedance L1, L2, L3	•	•	•	•	•	•
Apparent power L1, L2, L3, Σ L123	•	•	•	•	•	•
Active power L1, L2, L3, Σ L123	•	•	•	•	•	•
Requested power L1, L2, L3, L123 and Returned power L1, L2, L3, Σ L123	•	•	•	•	•	•
Reactive inductive power L1, L2, L3, Σ L123 and Reactive capacitive power L1, L2, L3, Σ L123	•	•	•	•	•	•
Power factor L1, L2, L3	•	•	•	•	•	•
Active power W L1, L2, L3, (Maximeter-integration programmable from 10 secs. to 15 mins.)	•	•	•	•	•	•
Active imported energy counters L1, L2, L3, Σ L123 from 0000000,00001 to 9999999,99999 kWh	•	•	•	•	•	•
Active exported energy counters L1, L2, L3, Σ L123 from 0000000,00001 to 9999999,99999 kWh	•	•	•	•	•	•
Reactive energy counters L1, L2, L3, Σ L123 from 0000000,00001 to 9999999,99999 kQh	•	•	•	•	•	•
DC voltage (Vdc) L1, L2, L3	•	•	•	•	•	•
AC voltage (Vac) L1, L2, L3	•	•	•	•	•	•
DC intensity (Idc) L1, L2, L3	•	•	•	•	•	•
AC intensity (Iac) L1, L2, L3	•	•	•	•	•	•
DC power(Wdc) L1, L2, L3	•	•	•	•	•	•
AC power (Wac) L1, L2, L3	•	•	•	•	•	•
Differential intensity DC (IDdc)	•	•	•	•	•	•
Differential intensity AC (IDac)	•	•	•	•	•	•
Voltage %HD (harmonic distortion) L1, L2, L3 of harmonic k 0 to 63 (64 harmonics)	•	•	•	•	•	•
Intensity %HD (harmonic distortion) L1, L2, L3, of harmonic k 0 to 63 (64 harmonics)	•	•	•	•	•	•
Voltage L1, L2, L3, of harmonic k 0 to 63 (64 harmonics)	•	•	•	•	•	•
Intensity L1, L2, L3, of harmonic k 0 to 63 (64 harmonics)	•	•	•	•	•	•

UNIVERSAL+ 7WR (3-year guarantee)	7WR					
Command configuration (protection device)	M1		M2		M3	
Single-phase 2-pole (M) only L1 / Three-phase 4-pole (T) L1, L2, L3	M	T	M	T	M	T
Protections/alarms: programmable in value and delay with automatic reclosure/intelligent reclosure (only commands 1,2 and 3)						
Alarms: programmable in value and delay (commands 1,2,3 and 4)						
RMS overvoltage L1, L2, L3	•	•	•	•	•	•
Set overvoltage: >300V RMS L1, L2, L3 (Progressive voltage/time trip curve - EN 50550 Standard)	•	•	•	•	•	•
Set overvoltage: >350V RMS L1, L2, L3 (Progressive voltage/time trip curve - EN 50550 Standard)	•	•	•	•	•	•
Set overvoltage: >400V RMS L1, L2, L3 (Progressive voltage/time trip curve - EN 50550 Standard)	•	•	•	•	•	•
Pk overvoltage L1, L2, L3	•	•	•	•	•	•
RMS low voltage L1, L2, L3	•	•	•	•	•	•
RMS intensity L1, L2, L3	•	•	•	•	•	•
Pk intensity L1, L2, L3	•	•	•	•	•	•
RMS differential intensity (IDn RMS)	•	•	•	•	•	•
Pk differential intensity (ID Pk)	•	•	•	•	•	•
Neutral intensity		•		•		•
Power1 W L1, L2, L3	•	•	•	•	•	•
Power2 W L1, L2, L3 (Maximeter-integration programmable from 10 secs to 15 mins.)	•	•	•	•	•	•
Power factor L1, L2, L3	•	•	•	•	•	•
Voltage and Intensity L1, L2, L3 From 2-63, programmable by harmonic and harmonics bracket.	•	•	•	•	•	•
Voltage unbalance L1, L2, L3		•		•		•
Intensity unbalance L1, L2, L3		•		•		•
Over-temperature	•	•	•	•	•	•
Low temperature	•	•	•	•	•	•
Over-humidity	•	•	•	•	•	•
Low humidity	•	•	•	•	•	•
Over-frequency L1, L2, L3	•	•	•	•	•	•
Low frequency L1, L2, L3	•	•	•	•	•	•
Phase sequence		•		•		•
Remote input 1 (digital input)	•	•	•	•	•	•
Remote input 2 (digital input)	•	•	•	•	•	•
Time programmer	•	•	•	•	•	•
Preemptive cut-off in the event of AC power failure – insufficient supply (not programmable)	•	•	•	•	•	•
Phase failure L1, L2, L3 (not programmable)		•		•		•
Individual MCB cut-off counters						
Event-counter for waveform logger L1, L2, L3.	•	•	•	•	•	•
Overvoltages V1, V2, V3.	•	•	•	•	•	•
Low voltages V1, V2, V3.	•	•	•	•	•	•
Intensity I1, I2, I3.	•	•	•	•	•	•
Differential intensity	•	•	•	•	•	•
Neutral intensity.		•		•		•
Power1 L1, L2, L3	•	•	•	•	•	•
Power2 W L1, L2, L3 (Maximeter-integration programmable from 10 secs to 15 mins.)	•	•	•	•	•	•
Voltage unbalance V1, V2, V3.		•		•		•
Intensity unbalance I1, I2, I3.		•		•		•
Voltage THD (total harmonic distortion) V1, V2, V3.	•	•	•	•	•	•
Intensity THD (total harmonic distortion) I1, I2, I3.	•	•	•	•	•	•
Over-temperature and Low temperature.	•	•	•	•	•	•
Over-humidity and Low humidity.	•	•	•	•	•	•
Over-frequency V1, V2, V3.	•	•	•	•	•	•
Low frequency V1, V2, V3.	•	•	•	•	•	•
Power factor L1, L2, L3.	•	•	•	•	•	•
Time programmer.	•	•	•	•	•	•
Phase sequence.		•		•		•
MCB (circuit-breaker).	•	•	•	•	•	•
Remote input 1 (digital input)	•	•	•	•	•	•
Remote input 2 (digital input)	•	•	•	•	•	•
Locking	•	•	•	•	•	•
Power OFF (AC power failure)	•	•	•	•	•	•
Total counter	•	•	•	•	•	•
Total accumulated counter (undeletable)	•	•	•	•	•	•
Precisions available in ±0.2% and ±0.4% , in intensity and voltage						
Basic precision: ± 0.2%	•	•	•	•	•	•
Basic precision: ± 0.4%	•	•	•	•	•	•
Measurements for 64 harmonics, distortion factor, harmonic distortion (rango in % and valor V – A) +THD						
Graphic and numerical display in WebServer.	•	•	•	•	•	•

UNIVERSAL+ 7WR (3-year guarantee)	7WR					
	M1		M2		M3	
Command configuration (protection device)	M	T	M	T	M	T
Single-phase 2-pole (M) only L1 / Three-phase 4-pole (T) L1, L2, L3	M	T	M	T	M	T
Real, incremental, test of differential (perform routinely)						
Real, incremental, manual test of differential (differential tester)	•	•	•	•	•	•
Incremental autotest of differential (before reclosing)	•	•	•	•	•	•
Autotest of differential every 1 sec.	•	•	•	•	•	•
Circuit-breaker trip test	•	•	•	•	•	•
Maximum and minimum measurement logs						
Maximum: voltage L1, L2 and L3	•	•	•	•	•	•
Maximum: voltage unbalance L1, L2 and L3	•	•	•	•	•	•
Maximum: intensity L1, L2 and L3	•	•	•	•	•	•
Maximum: differential intensity	•	•	•	•	•	•
Maximum: neutral intensity	•	•	•	•	•	•
Maximum: intensity unbalance L1, L2 and L3	•	•	•	•	•	•
Maximum: frequency V1, V2 and V3	•	•	•	•	•	•
Maximum: voltage THD (total harmonic distortion) L1, L2 and L3	•	•	•	•	•	•
Maximum: intensity THD (total harmonic distortion) L1, L2 and L3	•	•	•	•	•	•
Maximum: active power L1, L2 and L3 (Maximeter programmable from 10 secs to 15 mins.)	•	•	•	•	•	•
Maximum: apparent power L1, L2 and L3	•	•	•	•	•	•
Maximum: reactive inductive power L1, L2 and L3	•	•	•	•	•	•
Maximum: reactive capacitive power L1, L2 and L3	•	•	•	•	•	•
Maximum: temperature	•	•	•	•	•	•
Maximum: humidity	•	•	•	•	•	•
Minimum: voltage L1, L2 and L3	•	•	•	•	•	•
Minimum: frequency V1, V2 and V3	•	•	•	•	•	•
Minimum: temperature	•	•	•	•	•	•
Minimum: humidity	•	•	•	•	•	•
Alarms. Programmable enablement/disablement of 10 relays + 4 relays A, B, C and D of a remote UNIVERSAL+ 7WR unit via Internet/Intranet by one or more alarms						
Differential lock	•	•	•	•	•	•
MCB lock (Circuit-breaker)	•	•	•	•	•	•
Intensity lock	•	•	•	•	•	•
Lock upon neutral I, PF, THDI, I unbalance, Power 1 W and Power 2 W	•	•	•	•	•	•
Overvoltage	•	•	•	•	•	•
Low voltage	•	•	•	•	•	•
MCB (Circuit-breaker)	•	•	•	•	•	•
Intensity	•	•	•	•	•	•
Differential intensity	•	•	•	•	•	•
Neutral intensity	•	•	•	•	•	•
Power factor	•	•	•	•	•	•
Voltage THD (total harmonic distortion)	•	•	•	•	•	•
Intensity THD (total harmonic distortion)	•	•	•	•	•	•
Voltage unbalance	•	•	•	•	•	•
Intensity unbalance	•	•	•	•	•	•
Manual OFF from front panel	•	•	•	•	•	•
Manual OFF via Internet/Intranet	•	•	•	•	•	•
Over-temperature and Low temperature	•	•	•	•	•	•
Over-humidity and Low humidity	•	•	•	•	•	•
Over-frequency and Low frequency	•	•	•	•	•	•
Phase sequence	•	•	•	•	•	•
Remote input 1 (digital input)	•	•	•	•	•	•
Remote input 2 (digital input)	•	•	•	•	•	•
Time programmer	•	•	•	•	•	•
Timer 1, 2, 3 and 4 of module 1 (digital input IN1, IN2, IN3 and IN4 of module 1)	•	•	•	•	•	•
Timer 1, 2, 3 and 4 of module 2 (digital input IN1, IN2, IN3 and IN4 of module 2)	•	•	•	•	•	•
Power1 W	•	•	•	•	•	•
Power2 W (Maximeter-integration programmable from 10 secs to 15 mins.)	•	•	•	•	•	•
Reception of TCP/IP commands from other remote UNIVERSAL+ 7WR units via Internet/Intranet.						
For the enablement/disablement of relays A and B	•	•	•	•	•	•
Outstanding characteristics						
True RMS, Peak (Pk), AC and DC measurements (DC in intensity with DC)ine transformers)	•	•	•	•	•	•
Averaged RMS display, programmable 100, 200, 300, 400 and 500ms	•	•	•	•	•	•
Very high-speed MCB cut-off (2P=2ms, 4P=5ms)	•	•	•	•	•	•
Intelligent reclosures and sequential reclosures	•	•	•	•	•	•
Sequential, automatic or manual reclosures	•	•	•	•	•	•
Backlit, 12x3-character screen. Intuitive menus. Long texts: easy to read scroll-down	•	•	•	•	•	•
Chronological log of last cut-off. With value and year, month, day, hour and minute	•	•	•	•	•	•
Chronological log of last alarm. With value and year, month, day, hour and minute	•	•	•	•	•	•
Control external I/O modules: up to 14 logical outputs (relays) and 10 logical inputs, temperature and humidity probe, controls for logical inputs (Remotes In) programmable signal-action.	•	•	•	•	•	•
WebServer display, programming and remote control via Internet/Intranet	•	•	•	•	•	•
Independent programmable connection delays: in the event of cut-off by voltage alarms and cut-off in the event of power failure (delay from 0 to 999 s)	•	•	•	•	•	•
Manual connection and disconnection	•	•	•	•	•	•
4-digit protection PIN	•	•	•	•	•	•
Programmable acoustic warnings (enabled or disabled)	•	•	•	•	•	•
Ex-factory default configuration	•	•	•	•	•	•
High-precision time programmer in hours and minutes	•	•	•	•	•	•
Language: configurable in Spanish or English	•	•	•	•	•	•
DataWatchPro: Professional software for PC with database ,graphic data analysis , etc.	•	•	•	•	•	•

3.3 Description of connection terminals- UNIVERSAL+ 7WR M1 Differential, type A

Description of connection terminals- UNIVERSAL+ 7WR M1 Differential, type A	
A CONTROL OUT	OUTPUT TRIPPING COIL HIGH-SPEED DISCONNECTOR TERMINAL A
B CONTROL OUT	OUTPUT TRIPPING COIL HIGH-SPEED DISCONNECTOR TERMINAL B
L1 POWER 230V	SUPPLY TO PHASE L1 (LINE1) 230V L1-N AC + INPUT METERING SENSOR INPUT L1
N POWER 230V	SUPPLY TO NEUTRAL + INPUT METERING SENSOR INPUT N
L2 INPUT 2	INPUT2 METERING SENSOR L2 (LINE 2) 230V L2-N AC
N INPUT 2	INPUT2 METERING SENSOR N (NEUTRAL)
L3 INPUT 3	INPUT3 METERING SENSOR L3 (LINE 3) 230V L3-N AC
N INPUT 3	INPUT3 METERING SENSOR N (NEUTRAL)
I SENSOR 1	INPUT DIFFERENTIAL INTENSITY SENSOR1
G SENSOR 1	COMMON DIFFERENTIAL INTENSITY and TEST SENSOR1
T SENSOR 1	OUTPUT DIFFERENTIAL INTENSITY TEST SENSOR1
G SENSOR 2	COMMON INTENSITY SENSOR2 (max. intensity: 0,1A RMS)
I1 SENSOR 2	INPUT INTENSITY SENSOR2 L1(max. intensity: 0,1A RMS)
I2 SENSOR 2	INPUT INTENSITY SENSOR2 L2(max. intensity: 0,1A RMS)
I3 SENSOR 2	INPUT INTENSITY SENSOR2 L3(max. intensity: 0,1A RMS)
AUXILIARY IN-OUT	CONNECTION TO OF INPUT/OUTPUT RELAY MODULES TEMPERATURE/HUMIDITY PROBE, REMOTE IN1, IN2 USE ONLY SUPPLIED CABLE AND CONNECTORS (Consult the UNIVERSAL+ 7WR IN OUT and accessories, I/O relay modules, temperature and humidity probe manuals)
ETHERNET	ETHERNET RJ45 CONNECTION

3.4 Description of display panel

- 1 – Display: 12 characters in three alpha-numeric lines, 5x7 dot-matrix
- 2 – Green indicator LED (WORKING), slow flashing (1 Hz), indicates measurement and protection in progress
- 4 – Green indicator LED (WORKING), fast flashing (1/2 Hz), indicates an alarm has been detected
- 5 – Square yellow push-buttons: function depends on context:
 - MENU - ESC
 - NEXT (up)
 - TEST (down)
 - OK – RESET – (General Reset when held down more than 10 secs.)

3.5 Default alarm values ex-factory - UNIVERSAL+ 7WR M1 Differential, type A
Configuration: 230V 50Hz AC between phase and neutral, 400V AC 50Hz between phases

Alarm values which are restored when "Total reset and default configuration ex-factory" is executed in the menu				
Version: voltage measurement scale (Line Neutral): 500E and 1000E = full scale measurement line neutral 500V Pk and 1000V Pk				
Single-phase 2-pole (M) only L1 / Three-phase 4-pole (T) L1, L2, L3				
Alarm	Range Value	Value	Range Nbr Delay	Delay
ΔV Pk L1, L2, L3 (voltage difference Pk)	from 20 V to 200 V	40 V	Set	156,25 μ s
ΔV RMS L1, L2, L3 (RMS voltage difference)	from 1 V to 300 V	25 V	Set	20 ms
RMS overvoltage L1, L2, L3	245 – 276 V	265 V	(1 - 250) x 20 ms = (20 – 5000) ms	49 = 980 ms
Single-phase Pk overvoltage L1	350 – 450 V Pk	400 V Pk	(1 - 58) x 0,15625 ms = (0,156 – 9,062) ms	15 = 2,343ms
Three-phase Pk overvoltage L1, L2, L3	350 – 450 V Pk	400 V Pk	(1 - 58) x 0,15625 ms = (0,156 – 9,062) ms	22 = 3,437ms
RMS low voltage L1, L2, L3	180 – 210 V	185 V	(1 - 500) x 20 ms = (20 – 10000) ms	250 = 5000 ms
RMS overvoltage L1, L2, L3	Set	>300 V	Set	1000 ms
RMS overvoltage L1, L2, L3	Set	>350 V	Set	260 ms
RMS overvoltage L1, L2, L3	Set	>400 V (only version F.E. 1000V Pk)	Set	80 ms
RMS intensity L1, L2, L3	1 – 63 A	63 A	(1 - 500) x 20 ms = (20 – 10000) ms	250 = 5000 ms
Pk intensity L1, L2, L3	2 – 89 A Pk	89 A Pk	(3 - 58) x 0,15625 ms = (0,46 – 9,06) ms	55 = 8,593 ms
Neutral intensity	1 – 63 A	40 A	2 – 180 seconds	10 s
Power1 W L1, L2, L3	1 – 9999999 W	1000 W	1 – 999 seconds	10 s
Power2 W L1, L2, L3	1 – 9999999 W	1000 W	Maximeter programmable from 10 secs to 15 mins	15 min.
Power factor L1, L2, L3	0,99 – 0,01	0,4	2 – 180 seconds	10 s
Unbalance V L1, L2, L3	5 – 100 %	50 %	2 – 180 seconds	10 s
Unbalance I L1, L2, L3	5 – 100 %	90 %	2 – 180 seconds	10 s
Voltage THD L1, L2, L3	1 – 90 %	10 %	2 – 180 seconds	10 s
Intensity THD L1, L2, L3	1 – 90 %	80 %	2 – 180 seconds	10 s
Over-temperature	-40 a +100 °C	Alarm OFF \geq +50 °C NO alarm ON < +45 °C Value of OFF must be > value of ON	2 – 180 seconds	10 s
Low temperature	-40 a +100 °C	Alarm OFF < -10 °C NO alarm ON \geq -5 °C Value of OFF must be < value of ON	2 – 180 seconds	10 s
Over- humidity	10 – 90 %	Alarm OFF \geq 90 % NO alarm ON < 80 %	2 – 180 seconds	10 s
Low humidity	10 – 90 %	Alarm OFF < 10 % NO alarm ON \geq 20 %	2 – 180 seconds	10 s
Over-frequency L1, L2, L3	51 – 55 Hz	Alarm OFF \geq 55 Hz NO alarm ON < 54 Hz	2 – 180 seconds	10 s
Low frequency L1, L2, L3	45 – 49 Hz	Alarm OFF < 45 Hz NO alarm ON \geq 46 Hz	2 – 180 seconds	10 s
Phase sequence	-	-	2 – 180 seconds	10 s
Remote input 1	Normal or rocking	Normal	-	5 ms
Remote input 2	Normal or rocking	Normal	-	5 ms
Version: sensitivity IΔn 10-300 mA Differential, type A				
Alarm	Range Value	Value	Range Nbr Delay (50Hz RMS 1 = 20ms PK 1 = 0,15625 ms)	Delay
RMS differential intensity	10 – 300 mA	10 mA	If value \leq 35 mA (2) x 20 ms = (40) ms If value > 35 mA (4 - 50) x 20 ms = (80 – 1000) ms	2 = 40 ms
Pk differential intensity Enables ex-factory by default	14 – 424 mA Pk	14 mA Pk	If value \leq 50 mA (7 - 45) x 0,15625 ms = (1,09 – 7,03) ms If value > 50 mA (7 - 58) x 0,15625 ms = (1,09 – 9,06) ms	45 = 7,03 ms
Version: sensitivity IΔn 30-1000 mA Differential, type A				
RMS differential intensity	30 – 1000 mA	30 mA	If value \leq 35 mA (2) x 20 ms = (40) ms If value > 35 mA (4 - 50) x 20ms = (80 – 1000) ms	2 = 40 ms
Pk differential intensity Enables ex-factory by default	42 – 1414 mA Pk	42 mA Pk	If value \leq 50 mA (7 - 45) x 0,15625 ms = (1,09 – 7,03) ms If value > 50 mA (7 - 58) x 0,15625 ms = (1,09 – 9,06) ms	45 = 7,03 ms
Version: sensitivity IΔn 100-3000 mA Differential, type A				
RMS differential intensity	100– 3000 mA	100 mA	(4 - 150) x 20 ms = (80 – 3000) ms	5 = 100 ms
Pk differential intensity Disables ex-factory by default	141 – 4242 mA Pk	141 mA Pk	(7 - 58) x 0,15625 ms = (1,09 – 9,06) ms	45 = 7,03 ms
Functions				
Auto-Manual	Auto-manual	Auto		
Delays connection	0 – 999 s	0 s		
Time programmer	ON / OFF	ON		
External module 1	YES / NO	NO		
External module 2	YES / NO	NO		
Temp./Humidity probe	YES / NO	NO		

Attention: important

The RMS differential intensity alarm is pre-programmed at the factory:

I Δ n 10-300mA version: at 10 mA and 40 ms delay

This pre-programming is customized as per the user's request at 100 mA, 200 mA and 300 mA (delay RMS 80 ms)

I Δ n 30-1000mA version: at 30 mA and 40 ms delay

This pre-programming is customized as per the user's request at 300 mA, 500 mA and 1000 mA (delay RMS 80 ms)

I Δ n 100-3000mA version: at 100 mA and 100 ms delay

This pre-programming is customized as per the user's request at 300 mA, 1000 mA and 3000 mA (delay RMS 100 ms)

Note example version I Δ n 30-1000mA: When the RMS differential intensity alarm is programmed to a value I Δ n \leq 35 mA, the Pk alarm is automatically enabled permanently. In this case, the Pk alarm cannot be disabled in its configuration menu.

The Pk alarm must be permanently enabled in order to comply with the IEC 60947-2-B standard.

Note: example with the I Δ n 30-1000mA versión. When the RMS differential intensity alarm is programmed to a value I Δ n > 35 mA, the Pk differential intensity alarm is permanently disabled and cannot be enabled in its configuration menu.

The Pk alarm must be permanently disabled in order to comply with the IEC 60947-2-B standard.

Differential intensity alarm. RMS and Pk differential intensity protection , example version I Δ n 30-1000mA:

NOTE 1: RMS differential intensity, delay value is directly conditioned by the value of the alarm
For values ≤ 35 mA delay range set at 2 cycles (40ms). Delay RMS: 1 cycle = 20ms (50Hz)
For values > 35 mA delay range de 4 a 50 cycles (80ms a 1000ms). Delay RMS: 1 cycle = 20ms (50Hz)

NOTE 2: the value of the Pk differential intensity alarm is automatically recalculated when it is modified and the value of the RMS value is saved as:

$$P \text{ alarm value} = \sqrt{2} \times \text{RMS alarm value.}$$

The value of the Pk delay is directly conditioned by the value of the Pk alarm. Pk delay: 1 sample = 156,25us (50Hz)
For values ≤ 50 mA Pk delay range from 7 to 45 samples (1,09ms to 7,03ms). Permanently enabled alarm.
For values > 50 mA Pk delay range from 7 to 58 samples (1,09ms to 9,06ms). Permanently disabled alarm.

NOTE 3: Exception: when the value of the RMS differential intensity alarm $I\Delta n \leq 35$ mA:
In this case, the Pk differential alarm is permanently auto-enabled and the Pk delay can only be programmed in a range of 7 to 45 samples (1,09msto a 7,03ms).

IMPORTANT: For safety reasons, the standard establishes that a differential must cut off between 50% and 100% of its programmed I Δ n value. This unit is situated at midpoint in this range. This means that the I threshold is established 25% below the original programmed I Δ n value.

RMS differential intensity alarm: Cannot be disabled in its configuration menu

Pk differential intensity alarm if the RMS value ≤ 35 mA: permanently enabled. Cannot be disabled in its configuration menu.

Pk differential intensity alarm if the RMS value > 35 mA: permanently disabled. Cannot be enabled in its configuration menu.

3.6 Alarms which cut off the MCB/circuit-breaker of the UNIVERSAL+ 7WR M1 module. Differential, type A

Alarm Single-phase 2-pole (M) only L1 / Three-phase 4-pole (T) L1, L2, L3	Disconnects MCB/circuit-breaker	Can be enabled/disabled in configuration menu
RMS overvoltage L1, L2, L3	YES	NO
Pk overvoltage L1, L2, L3	YES	NO
RMS low voltage L1, L2, L3	YES	NO
RMS intensity L1, L2, L3	Selectable (YES / NO)	NO
Pk intensity L1, L2, L3	Selectable (YES / NO)	YES
RMS differential intensity (IDn RMS)	YES	NO
Pk differential intensity (ID Pk)	YES (I Δ n ≤ 35 mA), NO (I Δ n > 35 mA)	NO
Preemptive cut-off in the event of AC power failure	YES	NO
Phase failure L1, L2, L3	YES	NO
Manual OFF from front panel	YES	NO
Manual OFF via Internet/Intranet	YES	NO
Neutral intensity	Selectable (YES / NO)	YES
Power 1 W	Selectable (YES / NO)	YES
Power 2 W (Maximeter programmable from 10 secs to 15 mins.)	Selectable (YES / NO)	YES
Power factor L1, L2, L3	Selectable (YES / NO)	YES
Voltage THD L1, L2, L3	Selectable (YES / NO)	YES
Intensity THD L1, L2, L3	Selectable (YES / NO)	YES
Voltage unbalance L1, L2, L3	Selectable (YES / NO)	YES
Intensity unbalance L1, L2, L3	Selectable (YES / NO)	YES
Over-temperature	Selectable (YES / NO)	YES
Low temperature	Selectable (YES / NO)	YES
Over-humidity	Selectable (YES / NO)	YES
Low humidity	Selectable (YES / NO)	YES
Over-frequency L1, L2, L3	Selectable (YES / NO)	YES
Low frequency L1, L2, L3	Selectable (YES / NO)	YES
Phase sequence	Selectable (YES / NO)	YES
Remote input 1	Selectable (YES / NO)	NO
Remote input 2	Selectable (YES / NO)	NO
Time programmer	Selectable (YES / NO)	YES

3.7 Default alarm status (enabled/disabled) ex-factory - UNIVERSAL+ 7WR M1 Differential, type A

Alarm states which are restored when "Total reset and default configuration ex-factory" is executed in the menu		
Alarm	Enabled ex-factory by default	Can be enabled/disabled in configuration menu
Single-phase 2-pole (M) only L1 / Three-phase 4-pole (T) L1, L2, L3		
RMS overvoltage L1, L2, L3	YES	NO
Pk overvoltage L1, L2, L3	YES	NO
RMS low voltage L1, L2, L3	YES	NO
RMS intensity L1, L2, L3	YES	NO
Pk intensity L1, L2, L3	NO	YES
RMS differential intensity (IDn RMS)	YES	NO
Pk differential intensity (ID Pk) version: (IΔn 10-300 mA)	YES (IΔn ≤35 mA)	NO
Pk differential intensity (ID Pk) version: (IΔn 30-1000 mA)	YES (IΔn ≤35 mA)	NO
Pk differential intensity (ID Pk) version: (IΔn 100-3000 mA)	NO	NO
Preventive cut-off upon AC power failure	YES	NO
Phase failure L1, L2, L3	YES	NO
Neutral intensity	NO	YES
Power 1 W	NO	YES
Power 2 W (Maximeter programmable from 10 secs to 15 mins.)	NO	YES
Power factor L1, L2, L3	NO	YES
Voltage THD L1, L2, L3	NO	YES
Intensity THD L1, L2, L3	NO	YES
Voltage unbalance L1, L2, L3	NO	YES
Intensity unbalance L1, L2, L3	NO	YES
Over-temperature	NO	YES
Low temperature	NO	YES
Over- humidity	NO	YES
Low humidity	NO	YES
Over-frequency L1, L2, L3	NO	YES
Low frequency L1, L2, L3	NO	YES
Phase sequence	NO	YES
Remote input 1	YES	NO
Remote input 2	YES	NO
Time programmer	YES	YES

3.8 Alarms with programmable enablement/disablement of output relays (via one or more alarms)

Alarm	Enablement/disablement of output relays (10 relays) and relays A, B, C and D of a remote unit via Internet/Intranet
Differential lock	Yes, programmable
Circuit-breaker lock	Yes, programmable
Intensity lock	Yes, programmable
Lock upon neutral I, PF, THDI, I unbalance	Yes, programmable
Overvoltage	Yes, programmable
Low voltage	Yes, programmable
Circuit-breaker	Yes, programmable
Intensity	Yes, programmable
Differential intensity	Yes, programmable
Neutral intensity	Yes, programmable
Power 1 W	Yes, programmable
Power 2 W (Maximeter programmable from 10 secs to 15 mins.)	Yes, programmable
Power factor	Yes, programmable
Voltage THD	Yes, programmable
Intensity THD	Yes, programmable
Voltage unbalance	Yes, programmable
Intensity unbalance	Yes, programmable
Manual OFF from front panel	Yes, programmable
Manual OFF via Internet/Intranet	Yes, programmable
Over-temperature	Yes, programmable
Low temperature	Yes, programmable
Over-humidity	Yes, programmable
Low humidity	Yes, programmable
Over-frequency	Yes, programmable
Low frequency	Yes, programmable
Phase sequence	Yes, programmable
Remote input 1	Yes, programmable
Remote input 2	Yes, programmable
Time programmer	Yes, programmable
Timer 1 module 1 (digital input IN1 module 1)	Yes, programmable
Timer 2 module 1 (digital input IN2 module 1)	Yes, programmable
Timer 3 module 1 (digital input IN3 module 1)	Yes, programmable
Timer 4 module 1 (digital input IN4 module 1)	Yes, programmable
Timer 1 module 2 (digital input IN1 module 2)	Yes, programmable
Timer 2 module 2 (digital input IN2 module 2)	Yes, programmable
Timer 3 module 2 (digital input IN3 module 2)	Yes, programmable
Timer 4 module 2 (digital input IN4 module 2)	Yes, programmable

3.9 Default automatic reclosure values ex-factory

Reset to zero time of all the counters for number of reclosures (3–240 mins): Default time ex-factory: **15 minutes**

In the event of cut-off due to differential intensity	
Reclosures	00min:00sec. – 99min:59sec.
R1	03:00
R2	06:00
R3	12:00
R4	30:00
R5	60:00
R6	90:00
R7	90:00
R8	90:00
R9	90:00
R10	90:00
R11	90:00
R12	90:00
R13	90:00
R14	90:00
R15	90:00
R16	90:00
R17	90:00
R18	90:00
R19	90:00
R20	90:00
R21	90:00
R22	90:00
R23	90:00
R24	90:00
R25	90:00
R26	90:00
R27	90:00
R28	90:00
R29	90:00
R30	90:00
Nbr of reclosures: 0–30 10 reclosures ex-factory, by default	

In the event of cut-off due to MCB / Circuit-breaker	
Reclosures	03min:00sec. – 99min:59sec.
R1	03:00
R2	10:00
R3	30:00
R4	60:00
R5	90:00
R6	90:00
R7	90:00
R8	90:00
R9	90:00
R10	90:00
Nbr of reclosures: 0–10 3 reclosures ex-factory, by default	

In the event of cut-off due to intensity	
Reclosures	03min:00sec. – 99min:59sec.
R1	03:00
R2	10:00
R3	30:00
R4	60:00
R5	90:00
R6	90:00
R7	90:00
R8	90:00
R9	90:00
R10	90:00
Nbr of reclosures: 0–10 3 reclosures ex-factory, by default	

In the event of cut-off due to neutral intensity, power factor, THDI, I unbalance, Power1 and Power2 :	
Reclosures	03min:00sec. – 99min:59sec.
R1	03:00
R2	10:00
R3	30:00
R4	60:00
R5	90:00
R6	90:00
R7	90:00
R8	90:00
R9	90:00
R10	90:00
Nbr of reclosures: 0–10 3 Reclosures ex-factory, by default	

NOTE: If the number of reclosures = 0 or the number of automatic sequential reclosures has been exhausted, the unit blocks. Press RESET to unblock it.

NOTE: The total estimated time between the MCB/circuit-breaker/ancillary contactor cutting off and the subsequent reclosure is: 10 secs. Displaying alarm + reclosure cycle time + capacitor charge-up-time (0– 20 secs.) + 10 secs. start-up sequence.

Chapter 4 – User's/installation guide

4.1 Precautions / warnings for the user / installer

- Despite this unit's being of maximum safety, both from a design and features standpoint, the utmost care must always be taken when using it. It must not be used until its characteristics and mode of operation have been fully understood.
- It must be borne in mind that the unit resets the ancillary circuit-breaker automatically and this fact could cause injury to a careless operator or user. In order to avoid this:
all up-stream conductors are to be disconnected. (by means of switches, sectionalisers or others)
- The user/installer must program the parameters of the protections in the value and delay most suited to the type of installation and in accordance with the laws, directives and standards of the location/place/country.
- The user/installer must program the parameters of the sequential reclosures in number of reclosures (0 does not reclose) and time best adapted to the type of installation and in accordance with the laws, directives and standards of the location/place/country.
- The installation should be equipped with elements of protection against over-intensity (suitable fuses) The maximum intensity of the intensity measurement transformers must not be exceeded.
- The wiring of the installation and the installation itself must be foreseen so as to support the maximum intensity of the protection elements.
- Do not apply current nor use the unit until all its connections have been connected up and it has been correctly installed in a standard enclosure. Due to an eventual risk of breakage, once current has been supplied to the unit, its connections must not be disconnected/connected except in the case of supply for same (230V AC).
- Do not connect the unit to any voltages/frequencies other than those indicated. (please, refer to technical characteristics).
- Do not connect up to installations which may supply intensities of over 25 KA 10 KA or 6 KA (depending on ancillary MCB)
- Terminals A and B of "CONTROL OUT" must not be short-circuited under any circumstance whatsoever. Should this occur, irreversible damage would be caused to the module
- Caution: The unit's connecting terminals and the AUX. IN-OUT connector are not insulated from the mains. The Ethernet connector, however, does have insulation from the mains.
- Caution: do not use connecting terminals 12 and 14 of the General Electric TELE L-1 CA 24/60V disconnection coil.
- In the event of electrostatic discharges or electromagnetic emissions, the LCD screen might go blank (with no monitoring). This does not affect the unit's functioning. In order to reset the screen, press MENU. Nevertheless, the unit resets cyclically every 15 minutes.
- Do not expose to liquids or humidity.
- Do not drop, knock or expose to vibrations.
- Do not expose to sources of heat
- Do not expose to environmental temperatures, depending on version, below 0°, -25° C. or over 40°, 50°, 70° C.
- Do not expose to magnetic sources or emissions (electric motors and transformers, electro-magnets, radio frequency emitters, etc.).
- Under no circumstance whatsoever must the unit be opened and the interior manipulated. The safety seals must remain intact. Should they be broken, the correct functioning of the unit could be jeopardised.
- In the event of any of the above occurring, the authorised technical service must be contacted immediately in order for the unit to be checked.
- The unit must be completely disconnected from the mains before cleaning with a soft, dry cloth or brush.
- For security reasons, change the ex-factory PIN for a personalised one and *note it down in a safe place*.
- For safety reasons, it is recommended that the security protection be enabled to avoid any modification of the unit's parameters via Internet (WebServer in display and read-only mode).

ATTENTION - IMPORTANT!

This unit (MCB + shunt-trip, UNIVERSAL+ 7WR M1 module and eventual accessories) must be installed in a closed, standard enclosure, the only part within access of the user being its display and command panel.

The parameters displayed in inverted commas "-.-", indicate that the parameter and, therefore, its corresponding alarm are not implemented in this specific and, consequently, no operation is contemplated

The temperature and humidity in inverted commas "-.-" indicate that the temperature/humidity probe is either not enabled in the menu or that it has not been installed.

The logical status of the input/output modules displayed in inverted commas "-.-", indicates that the I/O modules are either not enabled in the menu or that they have not been installed.

Important - Positioning of the intensity toroidal transformers and individualised adjustment to their module

The toroidal transformers, be they differential intensity or intensity, are individually matched and adjusted to their corresponding Sureline module for L1, L2 and L3. Therefore, these elements can, under no circumstance whatsoever, be interchanged with others bearing the same reference and from other Sureline modules. Were these to be interchanged, the measurement obtained would be erroneous and operation in protections would be abnormal. Only the transformers supplied for the specific Sureline module can be installed. Each transformer indicates the model and serial number of the Sureline module for which it has been specifically matched and adjusted. For current transformers (L1, L2, L3) the line is specified on their label.

The toroidal transformer must of necessity be positioned as shown in the "Wiring diagrams", the direction of the arrow indicating the position with respect to the wiring. The length of the wire connecting the toroidal core to the SURELINE unit must not exceed 25cms.

- WIRING. PRECAUTIONS/WARNINGS FOR THE USER/INSTALLER

By way of a protective cover and to avoid contact and dust, the male connector, AUXILIARY IN/OUT, is fitted ex-factory covered with another female connector. This female connector is a protective cover and is not to be removed if not in use.

To remove this connector and connect in its turn the wired connector to the I/O modules, cut off the AC supply, remove this connector and replace it with the new wired female connector (only that supplied by the manufacturer). This connector cannot be manipulated with the unit live. Consult the UNIVERSAL+ 7WR IN OUT and accessories, I/O relay modules, temperature and humidity probe manuals.

All the connection terminals must be handled and connected with the unit totally disconnected from the AC supply and no interconnection can be effected with the unit live. It is of the utmost importance that **the correct polarity is ensured upon connection of the "L1, L2, L3" and "N" Sureline terminals**. If this polarity is not respected, the high accuracy is lost originating errors in measurement and abnormal functioning of the protections.

One risk of the unit not functioning correctly could be originated principally by an incorrect wiring up of the connection terminals. It is, therefore, of the **utmost importance that this wiring be carried out correctly in accordance with the following protocol:**

- ⤴ An homologated "male pin" is to be incorporated in the naked core of the stripped pliable conductor.
- ⤴ These terminals are placed in the corresponding grooves as far in as they will go.
- ⤴ Ensure that the conductor lead is correctly fixed with the pertinent tightening torque, i.e. there must be no displacement of the terminal nor any damage to the screws on head, thread, fillet or washer, any of which would be to the subsequent detriment of the assemblies and screw connections.

The user must periodically carry out the complete protection test as described in the section "Tests".

4.2 Transport and handling

This being a highly sophisticated electronic unit, it must be transported and handled with care as per the precautions stipulated in the foregoing section "Precautions / warnings".

4.3 Installation

The installation must be carried out by responsible, competent and qualified technical personnel once the present manual has been fully understood.

The location of the unit must meet the requirements and respect the precautions stipulated in the chapter "Precautions/warnings" and most especially the section "Very important"..

The unit must be installed in a standard single-phase installation, active phase and neutral having a difference of potential of 230V AC or a three-phase installation (3 phases + neutral) having a difference of potential from phases to neutral of 230V AC, and also a protection conductor of operative earth. Moreover, the installation must have, at its main switch panel, appropriate protections against over-intensities (fuses).

4.4 Wiring

The unit is fitted with top quality connection terminals. Each terminal has notches to enable easier fixing of the wires and prevent accidental removal. Likewise, the clamping screws have a self-fixing system which avoids their falling out should they work loose.

Moreover, the serigraphy identifies the corresponding counter-positioned terminals on the fanning strip. The graphic indications are backed up by intuitive identifying colours.

Connect terminals POWER L1 to line 1 (phase 1) and POWER N to the neutral of the 230V mains line, 50Hz sinusoidal alternating current- Connect the remaining terminals as indicated for the typical or chosen configuration. Please, refer to "Wiring diagrams"

It is imperative that the wiring of the terminals and the tightening of the screws in the fanning strip be effected correctly.

"Wiring diagrams" should be consulted. Should any doubt arise, the manufacturer or authorised distributor should be consulted.

Chapter 5 – Diagnoses and trouble-shooting

5.1 Diagnosis and solution

1. Error, detection of differential intensity toroidal transformer

The detectable anomalies can be: absence or failure of the toroidal core, fault in amplification electronic circuit, filtering, the analogical digital detection and conversion system differential intensity sensor circuit. In these cases, the unit shuts off and does not reclose, emitting a warning beep and displaying "Intensity toroidal not detected" There is an anomaly in the unit and it must be revised immediately. Do NOT use the unit. Consult the technical service. In order for this differential test to function correctly, the connections of the differential measurement toroidal to the module's terminals (leads I, G, T) must respect the wiring diagrams.

2. Test error (differential intensity test IΔn)

The unit shuts off and "Test error" is displayed on-screen accompanied by a long intermittent beep. There is an anomaly in the unit and it must be revised immediately. Do NOT use the unit. Consult the technical service.

After "Error test" is indicated on-screen, this is followed by "Test Error ID. Consult manual" and the unit will remain in a cut-off state.

In order for this differential test to function correctly, the connections of the differential measurement toroidal to the module's terminals (leads I, G, T) must respect the wiring diagrams.

3. Communication error real time clock

The unit indicates "Communication error, I2C clock not found,

There is an anomaly in the real-time clock module and must be checked immediately.

Do NOT use. Consult the technical service.

4. Communication error temperature and humidity probe

Verify the wiring of the temperature and humidity probe, cut off the supply to the unit and then switch on again. Go to the submenu "temperature and humidity probe", disable the probe and then enable it again.

There is an anomaly in the temperature and humidity probe. Do NOT use it. Consult the technical service.

5. Communication error external modules

Verify the wiring of the external modules, cut off the supply to the unit and to the modules and then switch the unit on again. Go to the submenu "External module I/O x" and disable the communications of the modules and then enable again.

There is an anomaly in one or both the external modules. Do NOT use them. Disable them and consult the technical service.

6. "Incorrect user pin"

The user has entered the PIN incorrectly prior to pressing "Save" or "Send".

7. "Remote unit not found. Check configuration."

Some parameter in "Remote unit TCP/IP configuration" is not correct.

8. "Warning, command sent with pin error. Check configuration."

Some parameter in "Remote unit TCP/IP configuration" is not correct.

9. "Remote server not found. Check configuration."

Some parameter in "Remote unit TCP/IP configuration" is not correct.

10. "SST error"

Failure upon detection of physical memory for data storage.

11. "Warning, incoming command received with PIN error."

A command/order received from another unit or automated system with incorrect user PIN.

Chapter 6 – Verification and start-up**6.1 Start-up**

When starting up the installation, the unit's ancillary MCB is in the OFF position.

Connect all up-stream conductors by means of switches, sectionalisers or others. The reinitiation sequence will automatically be carried out. The ancillary MCB will then reset and the unit will be operative. Run the Differential Protection Test and verify its correct operation.

6.2 "Real incremental" differential intensity test ($I_{\Delta n}$)

This type of test injects a real sinusoidal intensity or voltage, of incremental value, which is added to the existent line measurement. Thus, when the alarm threshold is surpassed, this test originates an alarm/cut-off. In this way, one can know the value of cut-off.

- The differential intensity test injects an intensity into the line differential Intensity measurement toroidal core itself.

Before using the unit, the complete Protection Test must be run. If the unit is to be put to permanent use, testing must be done as a matter of routine. Once the test has been completed (section "Tests"), should the results not be correct, the unit must NOT be used under any circumstance whatsoever. The Authorised Technical Service must be contacted at once.

Functioning is correct when, once the Test button is pressed, the unit cuts off and emits the corresponding diagnosis and cut-off value. Moreover, the user must verify the threshold value at the moment of cut-off and the cut-off value, both of which must correspond to the programmed values.

The unit resets automatically once the sequential reclosures cycle is finalised. The user can press "reset" in order to reset manually.

In order for this differential test to function correctly, the connections of the differential measurement toroidal to the module's terminals (leads I, G, T) must respect the wiring diagrams.

6.3 Differential test with rated threshold

When "TEST $I_{\Delta n}$ ", is enabled, a real defect current of incremental value is generated in the measurement toroidal core. This is added to the existent differential leakage in the line. The test produces an alarm/cut-off when the alarm threshold is surpassed. In this way, the user can know cut-off value.

This differential PERMITS an "ideal" test to be carried out in a "normal" installation (with the habitual existent leakage). Other differentials, on the other hand, stick strictly to the Standard tolerated margins and provoke a defect current 125% superior to the rated value. Moreover, adding to that, the existent differential leakage in the line, 150% could easily be reached which *does not constitute any proof that these differentials will function at said rated value.*

6.4 Differential intensity test - $I_{\Delta n}$ (differential tester)

When "TEST $I_{\Delta n}$ ", is enabled, a real defect current of incremental value is generated in the measurement toroidal core. This is added to the existent differential leakage in the line. The test produces an alarm/cut-off when the alarm threshold is surpassed. In this way, the user can know cut-off value. Functioning is correct when, once the Test button is pressed, the unit cuts off and emits the corresponding diagnosis and cut-off value.

"Test" injects a real incremental value signal in the differential toroidal core (A type). This action checks out the toroidal core, the electronic amplification and filtering circuit and the analogic digital detection and conversion system.

Verification by the user himself of the cut-off value. This must correspond approximately to that programmed.

It is recommended that the test be carried out with an 80mS delay of the differential alarm, or lower if the value is <36mA.

Depending on the delay of the differential alarm, the cut-off value increases (the longer the delay, the greater the increase)

With an 80mS delay, the approximate increase is +2% to +15% depending on the programmed (the greater the value, the smaller the increase)

When the differential alarm goes off, the following informative screen appears:

Test I D Intensity D 150.0 mA	→ Diagnosis of alarm causing cut-off → Cut-off value to be verified
-------------------------------------	--

10 seconds after alarm informing, the following screen appears concerning reclosure. The unit proceeds with the corresponding reclosure cycle.

Cycle R(1) Time to next reclosure 02m: 38s
--

Should one not wish to wait the reclosure time (3mins), press RESET and then OK/RESET and the unit will carry out the reboot sequence and will reclose the ancillary circuit-breaker (For further details regarding reclosure cycles, please, refer to "Sequential reclosures")

In order for this differential test to function correctly, the connections of the differential measurement toroidal to the module's terminals (leads I, G, T) must respect the wiring diagrams.

6.5 External WD (Watchdog) test

When this TEST is enabled, the unit cuts off. Should the unit not cut off, this means there is an anomaly and the unit must be revised immediately. Do NOT use it and contact the technical service. The test is functioning correctly when the unit cuts off and then recloses.

6.6 MCB (circuit-breaker) test

When I this TEST is enabled, the unit cuts off. Should the unit not cut off, this means there is an anomaly and the unit must be revised immediately. Do NOT use it and contact the technical service. The test is functioning correctly when the unit cuts off and then enters into the reclosure cycle (MCB). It will then reset. The user can press "reset" in order to reset manually.

6.7 "Real incremental" autotest of differential protection

The unit automatically carries out a "real incremental" test of the differential protection before each reconnection. It verifies that the operativity is currently valid as regards the toroidal, amplification, filtering and detection. In order for this differential test to function correctly, the connections of the differential measurement toroidal to the module's terminals (leads I, G, T) must respect the wiring diagrams.

6.8 Autotest of differential

The unit automatically carries out a test of the differential protection every second if $I_{\Delta n} < 10\text{mA}$. It verifies that the operativity is currently valid as regards the toroidal, amplification, filtering and detection. If $I_{\Delta n} > 10\text{mA}$, this check is not carried out since it considers that the toroidal, amplification, filtering and detection are all currently operative. In order for this differential autotest to function correctly, the connections of the differential measurement toroidal to the module's terminals (leads I, G, T) must respect the wiring diagrams.

When the autotest detects an anomaly, it cuts off and diagnoses. If the anomaly is subsequently resolved, then the unit recloses automatically. The user must check the performance and its threshold (cut-off value) manually by means of "TEST $I_{\Delta n}$ ", since this involves a disconnection.

6.9 Diagnosis of cut-off

The causes of cut-off are stored in memory and displayed on LCD screen.

6.10 Redundant cut-off devices

As a redundant security measure, the unit has a built-in dual cut-off device for the ancillary MCB, viz:

- Device #1: *high-speed* cut-off, by means of a tripping coil
- Device #2: cut-off by means of a built-in motor-drive

Moreover, in order to command the dual cut-off device, the unit has **two independent cut-off circuits**, viz:

1 - *High-speed* cut-off circuit for the MCB by means of a tripping coil. It has its own exclusive built-in energy storage which permits it to disconnect the MCB even when there is no mains supply.

2 - Cut-off circuit by means of a motor-drive. Permits disconnection and connection of the ancillary MCB. It has its own exclusive built-in energy storage which permits it to disconnect and connect the MCB even when there is no mains supply.

- NOTE1: The ancillary MCB (circuit-breaker) is cut off by means of a double cut-off device of all the protections/alarms. In the event of several simultaneous alarms, the ancillary MCB will cut off firstly via device 1 (tripping coil) and then 10 seconds later (time alarm indicated on display) also via device 2 (reclosure motor).
- NOTE 2: If the unit includes the option of having the oscilloscope event-logger, cut-off of the ancillary circuit-breaker is carried out by means of a dual cut-off in all the protections/alarms except in the case of an alarm or alarms acting on the circuit-breaker and the event-logger at one and the same time. In this case, cut-off is first effected by device #1 (tripping coil) and, 10 seconds later (indication time of the alarm), it cuts off by means of device #2 (reclosure motor-drive).

Chapter 7 – Description of protections

7.1 Differential protection

By “defect currents which derive, or leak to earth”, one is referring to those currents which derive to earth causing a difference in intensity between the live output conductors (phases and neutral).

If the leakage or derivation closes the circuit between phases and/or neutral of the live output conductors, there is no difference in intensity between phase and neutral. In this case, the differential protections do not act but then neither would any receiver being supplied from phase to neutral.

The functioning of the protection devices against defect currents which derive or leak to earth (differentials) is based on the measurement of the difference in intensity between the live conductors (phase and neutral). Once the pre-established threshold has been surpassed, the cut-off elements of the device come into play.

The differential is a standard element of protection. It measures defect currents to earth in order to cut off should this leakage exceed certain pre-established values.

For safety reasons, the norm stipulates that a differential must cut off within 50% and 100% of its programmed $I_{\Delta n}$ rated value. Sureline is situated midway in this range, i.e. the threshold is established at 25% below the original programmed $I_{\Delta n}$ value. As a norm, all differential manufacturers establish this margin in the same way (25% below the original programming value).

7.2 Protection against permanent and transient overvoltage (Progressive performance curve Voltage/Time RMS-Pk)

In the event of a permanent or transient overvoltage of a value superior to that programmed, the unit engineers a **high speed or a high-speed** cut-off via the tripping coil and the motor-drive.

The unit withstands permanent overvoltages of 450V RMS (L-N) and transient (300ms) 1000V peak voltages (L-N).

From 1000V L-N Peak upwards, the unit protects itself by means of a built-in fuse. Prolonged use in higher-rank voltages (300-450V L-N) is not recommended. The unit will reset automatically when the anomalous condition desists. Whilst there exists an overvoltage, the unit will not reset (Automatic Intelligent Reclosure).

- **Adjustment of the suitable level of voltage protection:** It is that level which does not surpass the maximum limits withstood by the receivers (loads, equipment....) in the installation, as established by the manufacturers. The great majority of manufacturers of devices and equipment declares 265V L-N to be the *maximum withstandable supply level*. In consequence, the user must establish and program a maximum level of protective performance equal or inferior to 265V L-N as suitable in order to ensure an efficient protection. One should consult the manuals of the receiving devices and regulate the threshold and delay in accordance with the manufacturers' specifications.

7.3 Adaptation to Standard EN 50550:2011

In order to adapt the voltage and delay values to those stipulated in Standard EN 50550:2011, the threshold and delay for RMS overvoltage protection must be programmed to a value of 275V and delay = 150 (3000 ms). Moreover, the threshold and delay for peak (Pk) overvoltage protection must be programmed to a value of 450V and delay = 45 (7,03 ms).

Thus, the progressive performance voltage/time curve will be as follows:

RMS overvoltage L1, L2, L3	>275V	3000ms	
RMS overvoltage L1, L2, L3	>300V	1000ms	
RMS overvoltage L1, L2, L3	>350V	260ms	
RMS overvoltage L1, L2, L3	>400V	80ms	
Pk overvoltage L1, L2, L3	>450VPk	7,03ms	(only version F.E. 1000V Pk)

In such cases, ensure that the receivers connected to the installation withstand said levels.

7.4 Protection against permanent and transient low voltage

In the event of a permanent or transient low voltage of a value inferior to that programmed, the unit engineers a **high speed** cut-off via the tripping coil and the motor-drive. Whilst there exists a low voltage, the unit will not reset (Automatic Intelligent Reclosure).

7.5 Protection against MCB tripping

The Sureline unit is equipped with an Automatic Sequential Reset of the ancillary MCB (programmable).

Chapter 8 – Additional options

The new universal range of protection, metering, register and automation/telecontrol units share the SURELINE philosophy and are extraordinarily versatile. So much so that they permit multiple configurations thanks to their modular expansion architecture not only with present and future SURELINE elements but also with others available on the market. Thus, they complement and are complemented by other characteristics and features regardless of whether or not they are Sureline's. Please, consult Safeline

8.1 Protection against intense transient overvoltages of very short duration (nS and μ S)

Thanks to its **high** physical cut-off **speed** and its wide voltage range, which ensure a constant supervision, along with its **intelligent reclosure** feature, the Sureline units are able to protect a vast gamut of situations. Nevertheless, there exist certain specific situations where there arise powerful but very brief transient overvoltages (μ S). In such a situation, the Sureline unit should be complemented with a specific protection.

This specific protection against these powerful but very brief transient (KV/ μ S) is provided by a module based on varistors, surge-arresters....

Albeit the protection method based on varistors is effective only in the event of very short-duration (μ S) transients, it does, however, constitute the ideal complement to the protections provided by the Sureline units.

The varistor affords a high derivation capacity together with a rapid response time which, thus, reduces the high values of the fore-mentioned transients.

Chapter 9 – Cut-off. Tripping times.

9.1 Total cut-off time of the MCB (circuit-breaker)

In the event of the protections being called into play, the cut-off of the ancillary MCB is effected in a typical time of between 2mS and 5mS in the 2-pole units (depending on the model and make of the MCB and coil employed). In the "L" version, the typical cut-off time is between 5mS and 10mS in the 2-pole units.

Available separately upon request, measurement protocol and also the corresponding graphics for the cut-off times of the different models and makes of ancillary MCB's and tripping coils.

Total cut-off time of the MCB

In order to calculate the total cut-off time in the event of protection acting, the additional programmed delay time of the alarm must be added to that shown on the graphs (typical cut-off time between 2mS and 5mS). Moreover, one must also bear in mind the ionisation effect at the moment of disconnection between the contacts of the ancillary cut-off element. Even though the starting point of the extinction of the intensity does not vary, the ionisation does prolong the duration. The factors which increase this time are directly proportional to the intensity and the voltage as well as the nature of the loads (inductive, capacitive or resistive).

Chapter 10 – Usage

Given the automatic nature of the diverse protections of the unit, after having read and fully understood the present manual and having started up the unit, the user may then proceed to connect up the elements of consumption to the protected line and the unit will operate as described in previous chapters.

Before using the unit, the complete Protection Test must be carried out, including the Watchdog test. If the unit is to be put to permanent use, testing must be done as a matter of routine. Once the test has been completed, should the results not be correct, the unit must not be used under any circumstance whatsoever. The Authorised Technical Service must be contacted immediately.

Should the user wish to disconnect the line and the unit, the circuit-breaker switch or sectionaliser at the main switchboard may be tripped manually (upstream) before the Sureline unit.

It must be borne in mind that the unit resets the ancillary circuit-breaker automatically and this fact could cause injury to a careless operator or user.

In order to avoid this: all up-stream conductors are to be disconnected. (by means of switches, sectionalisers or others).

Chapter 11 – Description of basic components

11.1 Differential intensity toroidal transformers (AC) TRDF18 and TRDF26 (Differential, type A)

Attention: They are individually matched and adjusted to the corresponding Sureline module and must under NO circumstance whatsoever, be interchanged with others.

Toroidal core (high magnetic permeability and low loss). Precision +/- 1.5%.

TRDF18 : internal \varnothing : 18mm

TRDF 26 : internal \varnothing : 26mm

- Other dimensions: Consult Safeline

11.2 Intensity toroidal transformers (AC) TRIT14 and TRIT18

Attention: They are individually matched and adjusted to the corresponding Sureline module and must under NO circumstance whatsoever, be interchanged with others. **For current transformers (L1, L2, L3) the line is specified on their label.**

Toroidal core (high magnetic permeability and low loss). Precision +/- 1%.

TRIT14 : internal Ø: 14mm

TRIT18 : internal Ø: 18mm

- Other dimensions: Consult Safeline

11.3 Ancillary MCB switch, 2 and 4-pole - Schupa (Gewiss Group)

Brand name: Schupa (Gewiss Group)
 Type: NLS10 ó NLS6
 Curve: C
 Intensities 6, 10, 16, 25, 32, 40, 50, 63A
 Breaking capacity 10kA or 6kA
 Mechanical endurance: MCB 2 and 4-pole: 20.000 complete manoeuvres (ON OFF)

For further information, consult the manufacturer

11.4 Cut-off device (tripping coil) - Schupa (Gewiss Group)

Brand name: Schupa (Gewiss Group)
 Type: NLS-F1 12/60V

For further information, consult the manufacturer

11.5 Ancillary MCB switch, 2 and 4-pole - G.E.

Brand name: General Electric
 Type: EP 60 (breaking capacity 10KA IEC 60947-2 or 6KA IEC 60898)
 Type: EP 100 (breaking capacity 15KA IEC 60947-2 or 10KA IEC 60898)
 Curve: C (standard), B, D, K
 Intensities 6, 10, 16, 25, 32, 40, 50, 63A
 Mechanical endurance: MCB 2 and 4-pole: 20.000 complete manoeuvres (ON OFF)

For further information, consult the manufacturer

11.6 Cut-off device (tripping coil) - G.E.

Brand name: General Electric
 Type: TELE L-1 CA 24/60V

For further information, consult the manufacturer

CHAPTER 12 – TECHNICAL SERVICE

12.1 Technical service

AUTHORISED TECHNICAL SERVICE: SOLELY BY THE MANUFACTURER

CHAPTER 13 – MAINTENANCE

13.1 Maintenance

Before using the unit, the complete Protection Test must be carried out as described in the section "Tests". If the unit is to be put to permanent use, testing must be done as a matter of routine.

Once the protection test has been completed, should the results not be correct, the unit must not be used under any circumstance whatsoever. The Authorised Technical Service must be contacted at once. This is also the case in the event of the eventualities described in the chapter "PRECAUTIONS".

Notwithstanding, on a minimal yearly basis, the user must check that the measurements of the electrical parameters of the unit coincide with those stipulated in the technical characteristics, To this end, competent technical personnel at the factory will revise the unit and proceed to calibrate it if need be.

The mechanical endurance of the Schupa 2 and 4-pole ancillary MCB is 20,000 complete manoeuvres (ON/OFF). It is recommended that the MCB, the tripping coil and the lever be changed pre-emptively after 10,000 manoeuvres.

La mechanical endurance of the General Electric 2-pole ancillary MCB is 20,000 complete manoeuvres (ON/OFF). It is recommended that the MCB, the tripping coil and the lever be changed pre-emptively after 10,000 manoeuvres.

La mechanical endurance of the General Electric 4P ancillary MCB is 15,000 complete manoeuvres (ON/OFF). It is recommended that the MCB, the tripping coil and the lever be changed pre-emptively after 8,000 manoeuvres.

NOTE: Consult "Cut-off counters".

Total accrued counter (undeletable) T.acum =10,000

(Consult the manufacturer regarding the electrical and mechanical endurance of the external circuit-breaker and accessories.

Chapter 14 – Guarantee

14.1 Guarantee card

GUARANTEE CARD (photocopy or print and send to Safeline)

Sureline model
 Serial nbr
 Date of purchase

Stamp of establishment where unit purchased (with complete address)

.....

Complete name and address of purchaser

.....

e-mail

Main use to which the Sureline unit is to be put

Notes

.....

I hereby authorise Safeline to keep me periodically informed Yes No

GUARANTEE

SAFELINE, S.L., as a leader in the field of electrical and electronic safety equipment endeavours to maintain an extensive service along with up-dated information to the users of its products. To this end, it is indispensable that the user fills out and returns the present guarantee further to purchase of his SURELINE unit.

Period of guarantee: three years as from date of purchase.

Conditions and application of the SURELINE guarantee: Your SURELINE unit is guaranteed against any defect of manufacture or original components as determined by our Technical Service. Any repair or substitution does not extend the guarantee period.

The guarantee covers::

- Reception of the unit for its repair or servicing.
- Cost of all components, replacements and labour on original components

The guarantee does not cover:

- Transport.
- Breakdown caused by non-original components or devices
- Defects caused by incorrect installation.
- Damage caused by incorrect usage, or errors arising from repairs and internal manipulation by unauthorised persons.
- .- Consumables: fuses, thermal fuses, varistors and labour involved in replacement of same

The guarantee is automatically forfeited in the event of:

- Breakage or deterioration of the seals of any of the original SURELINE elements
- Incorrect usage due to non-observance of the recommendations given in the SURELINE manual.

Repair service: All repair service, both within and outside of the guarantee period, is by SAFELINE, S.L. and its Authorised Technical Assistance Services.

Chapter 15 – Wiring diagrams
15.1 Wiring diagrams

UNIDAD UNIVERSAL+ 7WR M1
VERSION INTENSIDAD DIFERENCIAL TIPO A

MODELO UNIVERSAL+ 7WR - M1 - M

CONFIGURACION MONOFASICA 2 POLOS 6, 10, 16, 20, 25, 32, 40, 50, 63A.



VERSION INTENSIDAD DIFERENCIAL TIPO A

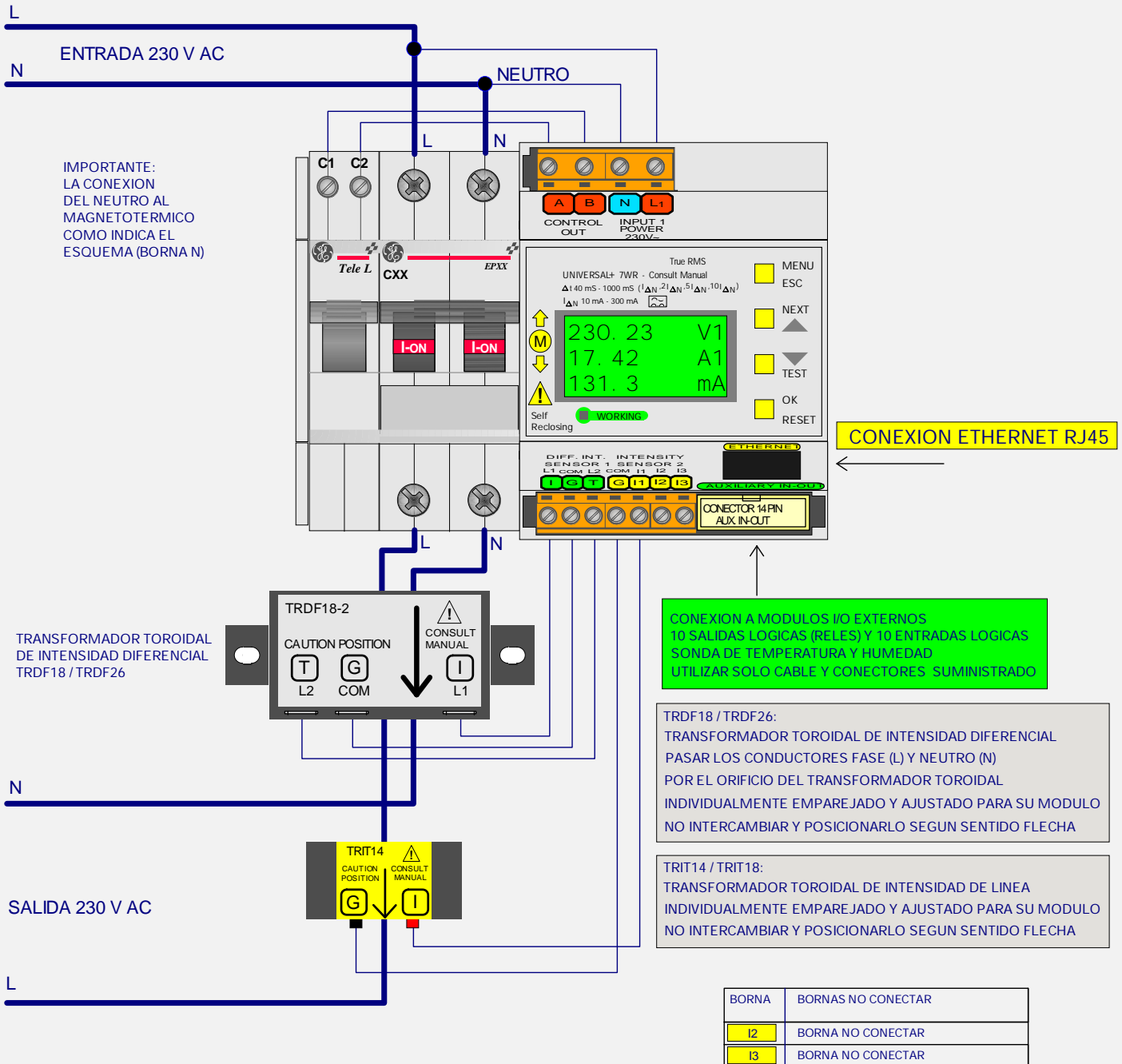

CONSULTAR MANUAL DE INSTRUCCIONES

UNIDAD UNIVERSAL+ 7WR M1 VERSION INTENSIDAD DIFERENCIAL TIPO A CON UNIVERSAL+ 7WR IN OUT (5 RELES DE SALIDA Y 5 ENTRADAS LOGICAS)

MODELO UNIVERSAL+ 7WR - M1 - M

CONFIGURACION MONOFASICA 2 POLOS 6, 10, 16, 20, 25, 32, 40, 50, 63A.

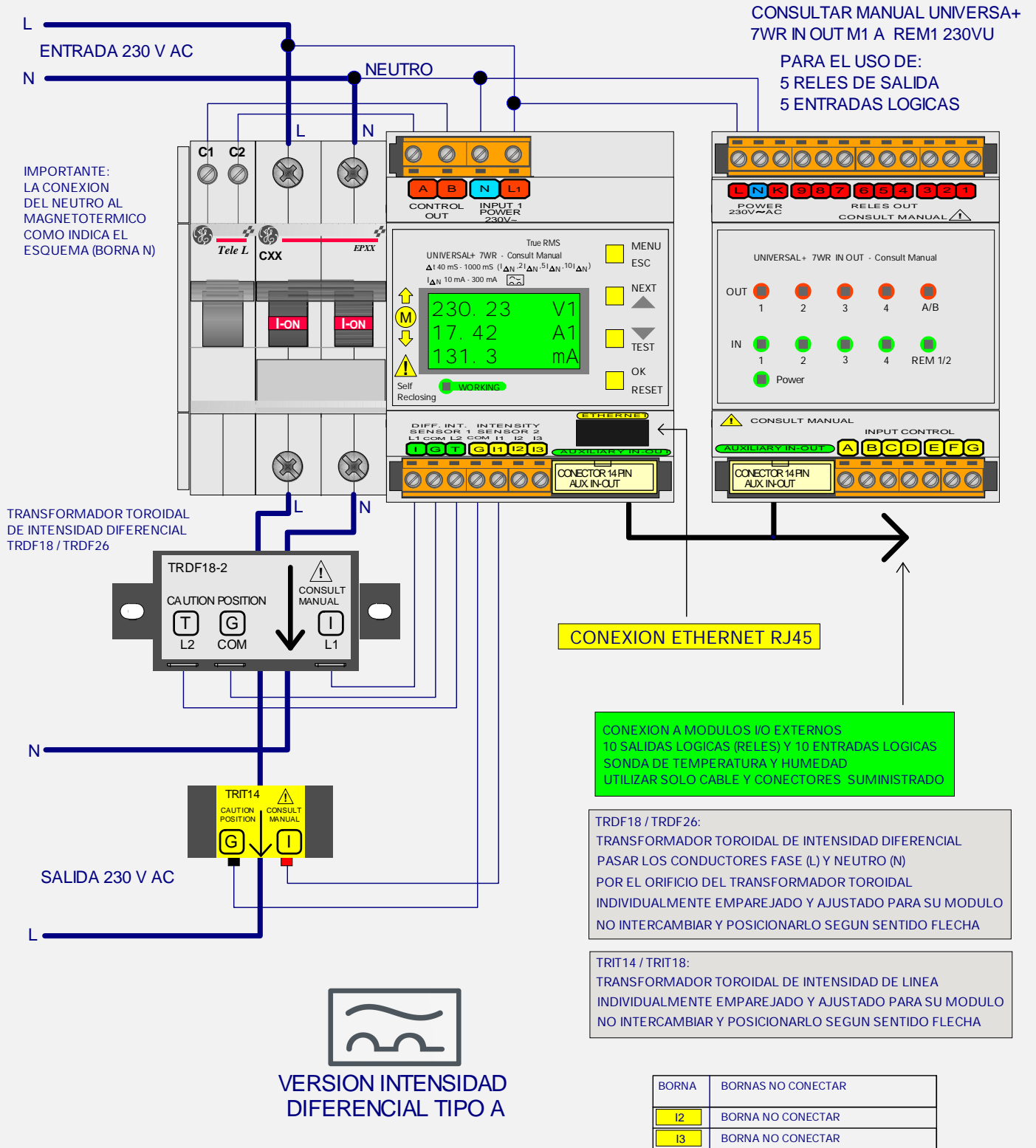

CONSULTAR MANUAL DE INSTRUCCIONES

UNIDAD UNIVERSAL+ 7WR M1

MODELO UNIVERSAL+ 7WR - M1 - M - N

CONFIGURACION MONOFASICA 2 POLOS 6, 10, 16, 20, 25, 32, 40, 50, 63A.

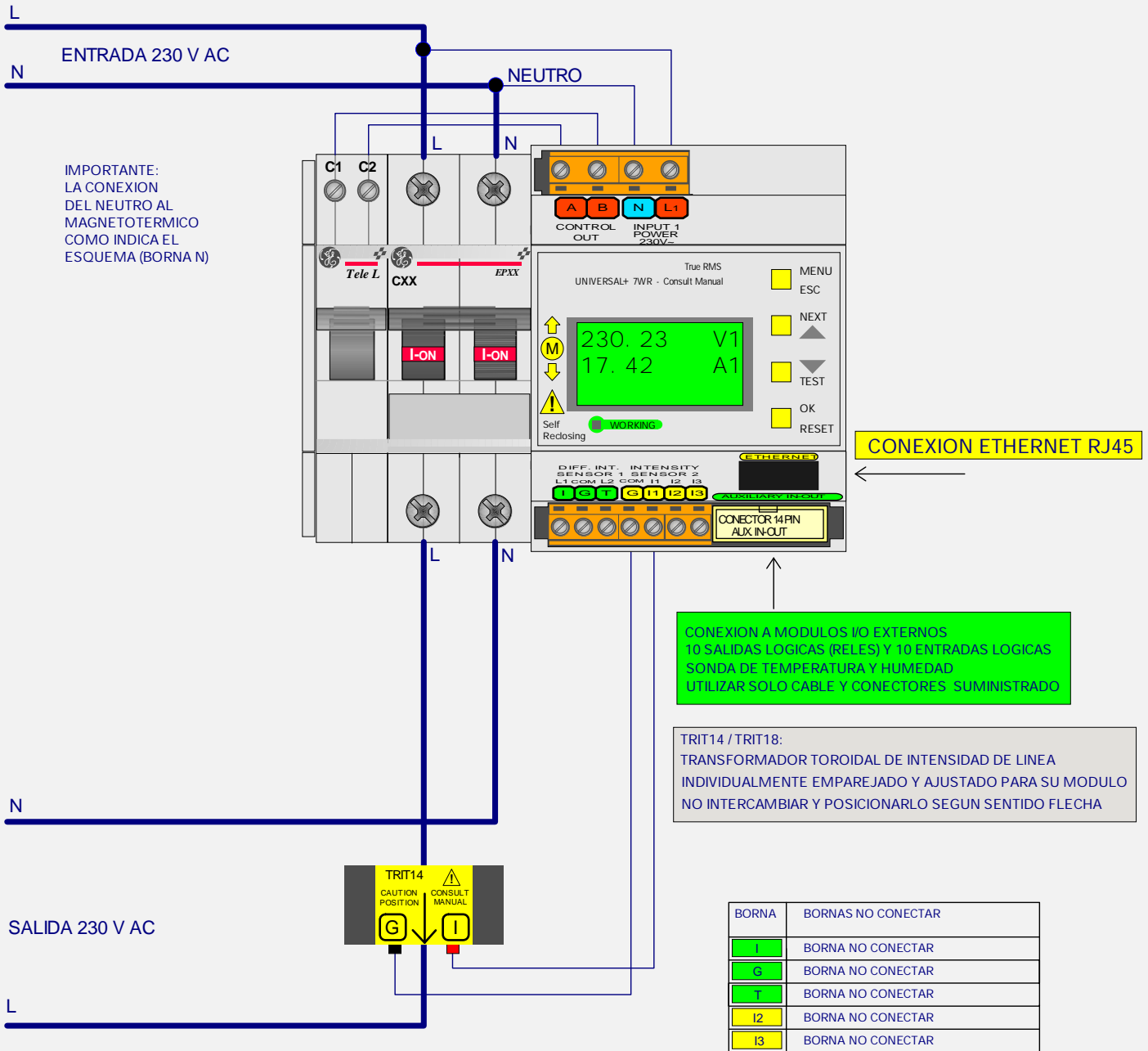

CONSULTAR MANUAL DE INSTRUCCIONES

UNIDAD UNIVERSAL+ 7WR M1 VERSION INTENSIDAD DIFERENCIAL TIPO A

MODELO UNIVERSAL+ 7WR - M1 - T

CONFIGURACION TRIFASICA 4 POLOS 6, 10, 16, 20, 25, 32, 40, 50, 63A.



VERSION INTENSIDAD
DIFERENCIAL TIPO A

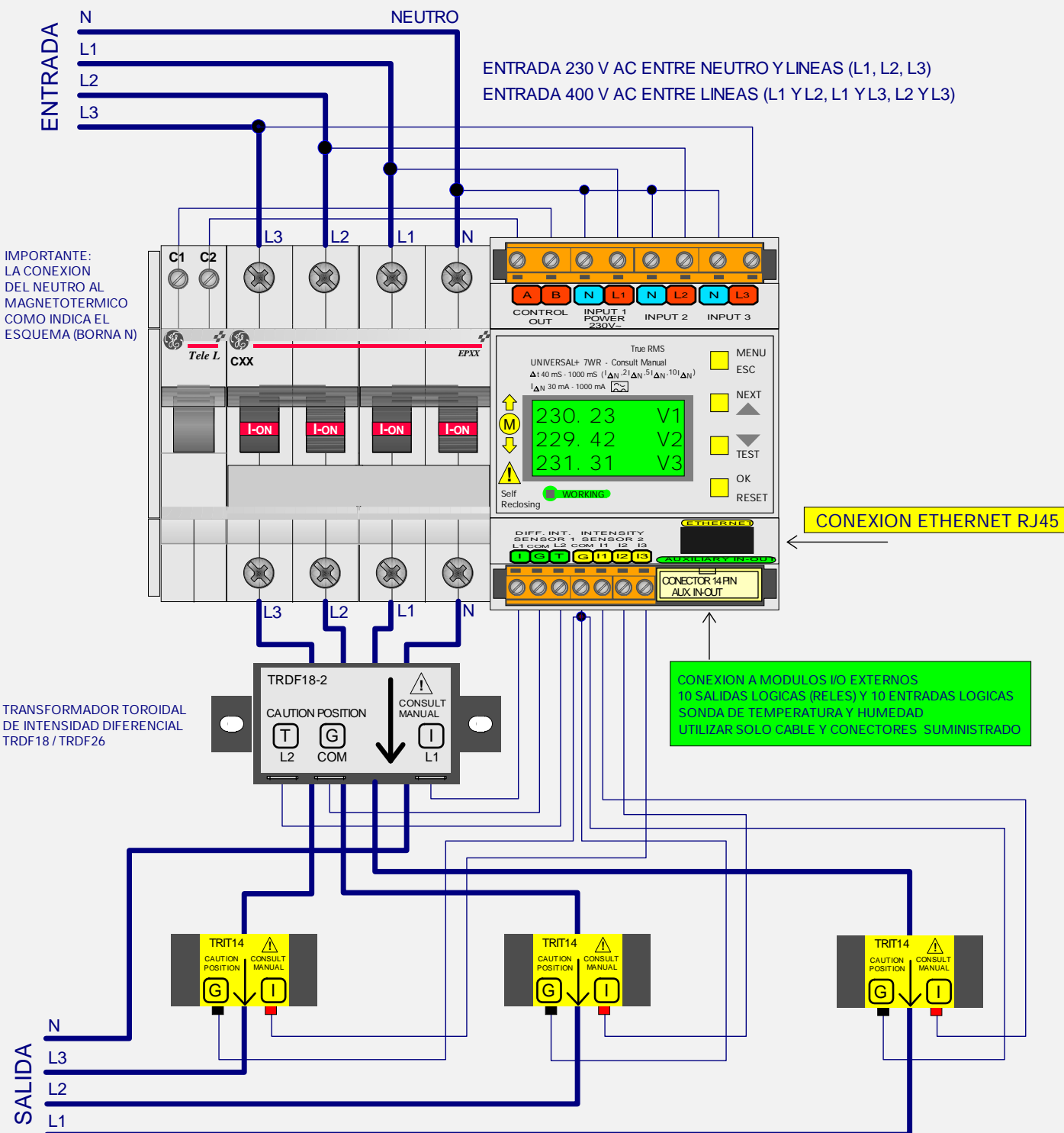

IMPORTANTE:
LA CONEXION
DEL NEUTRO AL
MAGNETOTERMICO
COMO INDICA EL
ESQUEMA (BORNA N)

ENTRADA 230 V AC ENTRE NEUTRO Y LINEAS (L1, L2, L3)
ENTRADA 400 V AC ENTRE LINEAS (L1 Y L2, L1 Y L3, L2 Y L3)

CONEXION ETHERNET RJ45

CONEXION A MODULOS I/O EXTERNOS
10 SALIDAS LOGICAS (RELES) Y 10 ENTRADAS LOGICAS
SONDA DE TEMPERATURA Y HUMEDAD
UTILIZAR SOLO CABLE Y CONECTORES SUMINISTRADO

TRANSFORMADOR TOROIDAL
DE INTENSIDAD DIFERENCIAL
TRDF18 / TRDF26

TRDF18 / TRDF26:
TRANSFORMADOR TOROIDAL DE INTENSIDAD DIFERENCIAL
PASAR LOS CONDUCTORES L1, L2, L3 Y NEUTRO
POR EL ORIFICIO DEL TRANSFORMADOR TOROIDAL
INDIVIDUALMENTE EMPAREJADO Y AJUSTADO PARA SU MODULO
NO INTERCAMBIAR Y POSICIONARLO SEGUN SENTIDO FLECHA

TRIT14 / TRIT18:
TRANSFORMADOR TOROIDAL DE INTENSIDAD DE LINEA
INDIVIDUALMENTE EMPAREJADO Y AJUSTADO PARA SU MODULO
NO INTERCAMBIAR Y POSICIONARLO SEGUN SENTIDO FLECHA



CONSULTAR MANUAL DE INSTRUCCIONES

UNIDAD UNIVERSAL+ 7WR M1 VERSION INTENSIDAD DIFERENCIAL TIPO A CON UNIVERSAL+ 7WR IN OUT (5 RELES DE SALIDA Y 5 ENTRADAS LOGICAS)

MODELO UNIVERSAL+ 7WR - M1 - T

CONFIGURACION TRIFASICA 4 POLOS 6, 10, 16, 20, 25, 32, 40, 50, 63A.



VERSION INTENSIDAD DIFERENCIAL TIPO A

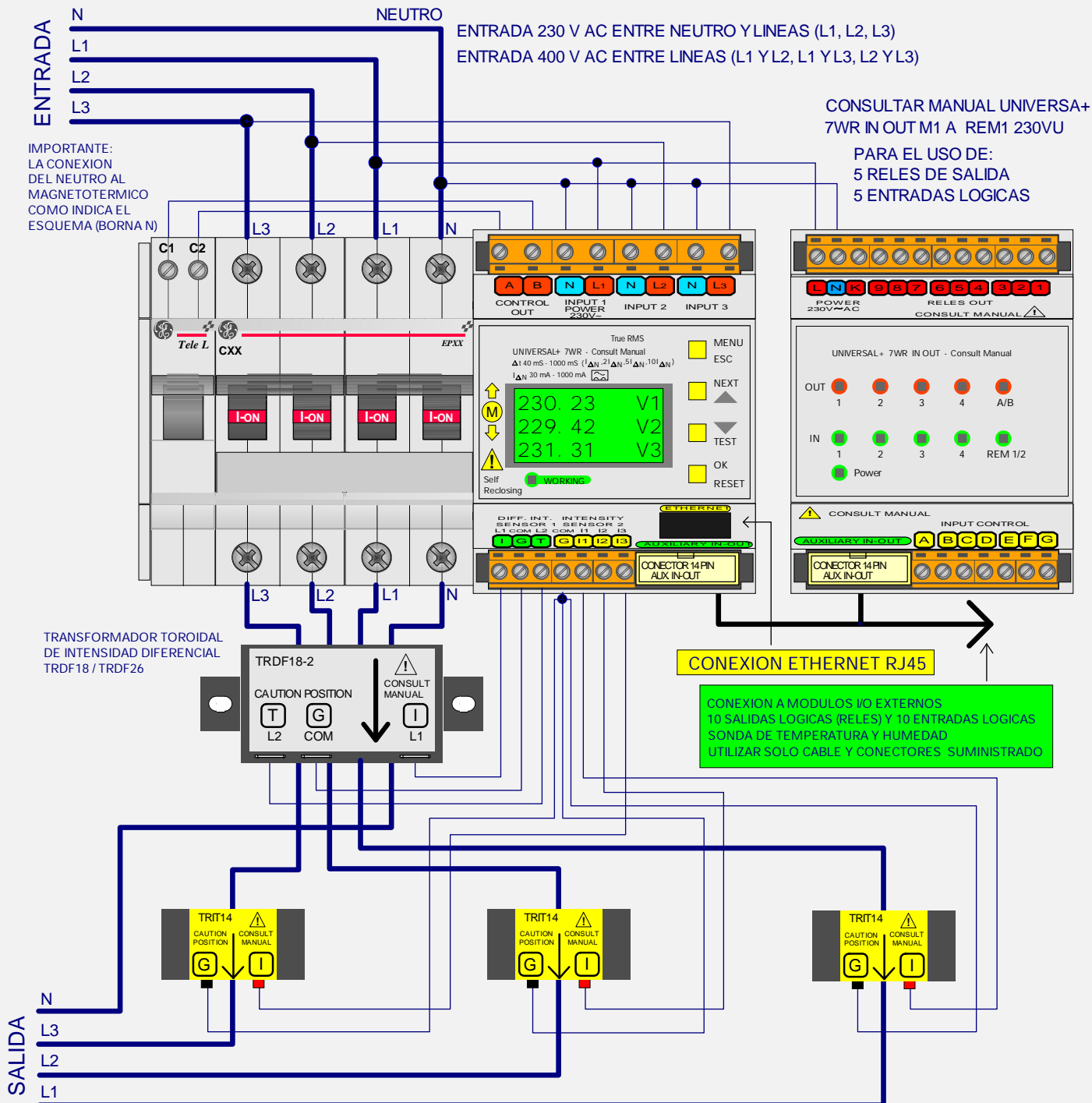

TRDF18 / TRDF26:
TRANSFORMADOR TOROIDAL DE INTENSIDAD DIFERENCIAL PASAR LOS CONDUCTORES L1, L2, L3 Y NEUTRO POR EL ORIFICIO DEL TRANSFORMADOR TOROIDAL INDIVIDUALMENTE EMPAREJADO Y AJUSTADO PARA SU MODULO NO INTERCAMBIAR Y POSICIONARLO SEGUN SENTIDO FLECHA

TRIT14 / TRIT18:
TRANSFORMADOR TOROIDAL DE INTENSIDAD DE LINEA INDIVIDUALMENTE EMPAREJADO Y AJUSTADO PARA SU MODULO NO INTERCAMBIAR Y POSICIONARLO SEGUN SENTIDO FLECHA



CONSULTAR MANUAL DE INSTRUCCIONES

UNIDAD UNIVERSAL+ 7WR M1

MODELO UNIVERSAL+ 7WR - M1 - T - N

CONFIGURACION TRIFASICA 4 POLOS 6, 10, 16, 20, 25, 32, 40, 50, 63A.

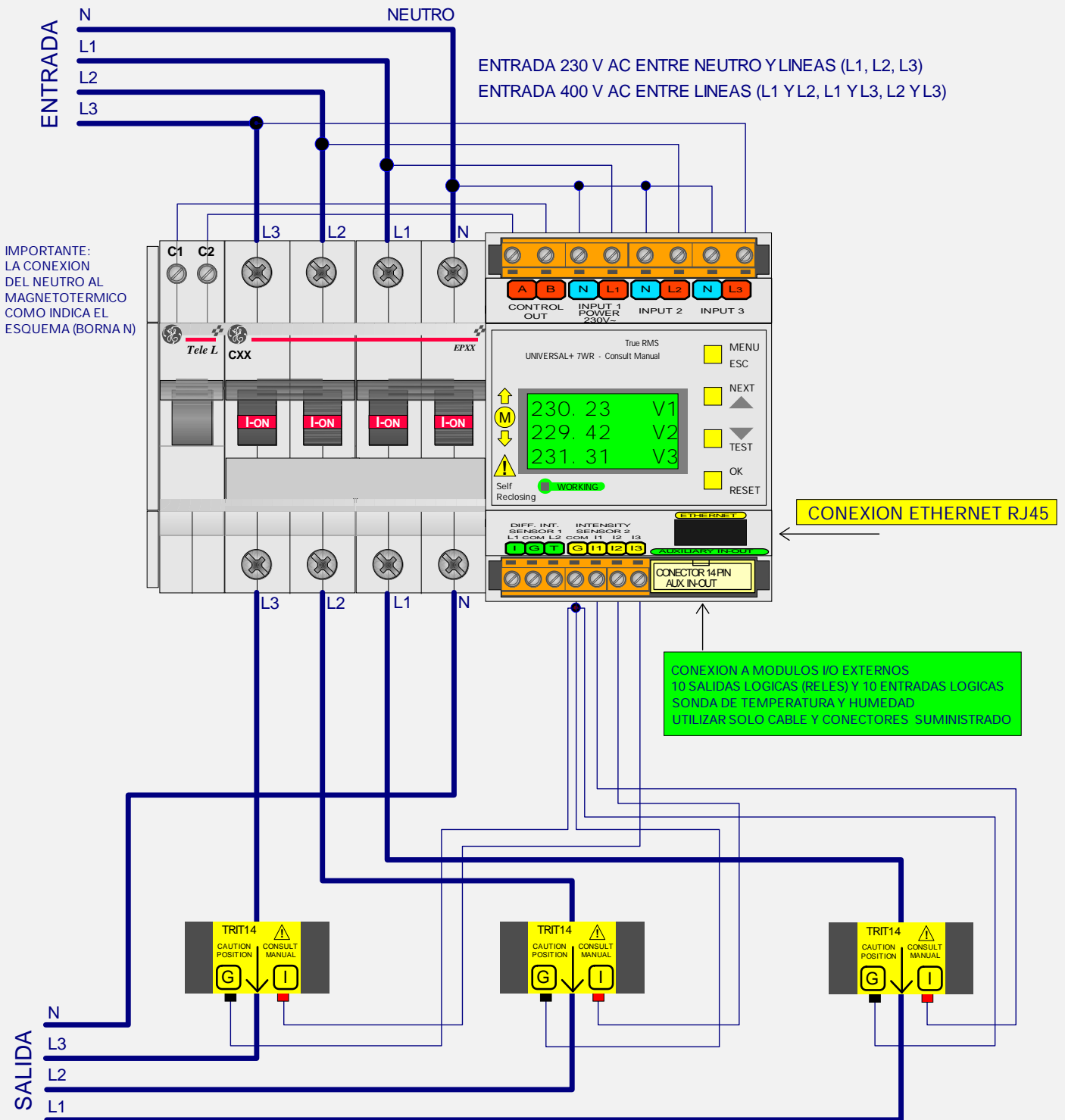

BORNA	SENSOR 1 BORNAS NO CONECTAR
	BORNA NO CONECTAR
	BORNA NO CONECTAR
	BORNA NO CONECTAR

TRIT14 / TRIT18:
TRANSFORMADOR TOROIDAL DE INTENSIDAD DE LINEA
INDIVIDUALMENTE EMPAREJADO Y AJUSTADO PARA SU MODULO
NO INTERCAMBIAR Y POSICIONARLO SEGUN SENTIDO FLECHA



CONSULTAR MANUAL DE INSTRUCCIONES

DIMENSIONES TRANSFORMADOR TOROIDAL DE INTENSIDAD DE LINEA

TRIT14

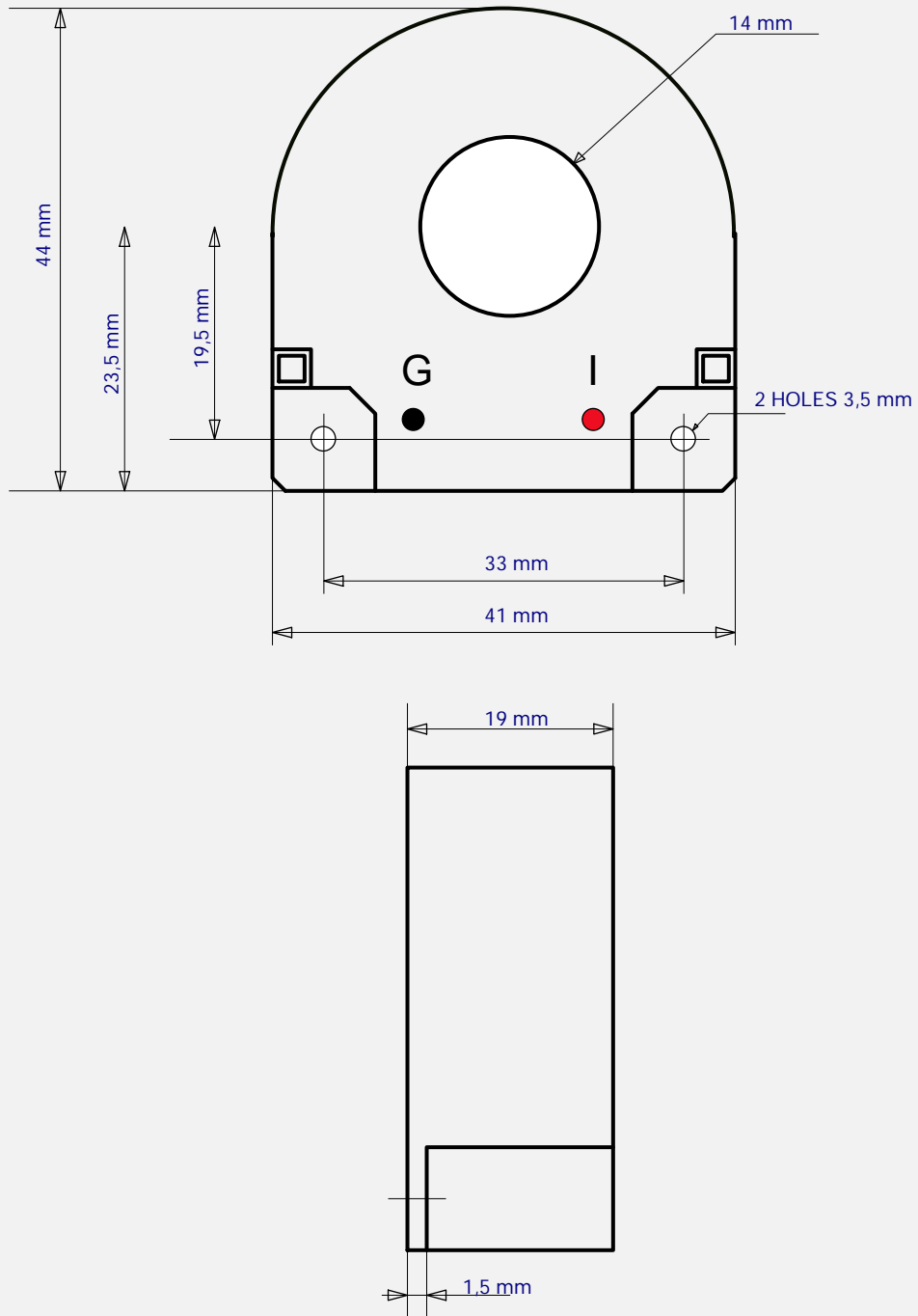

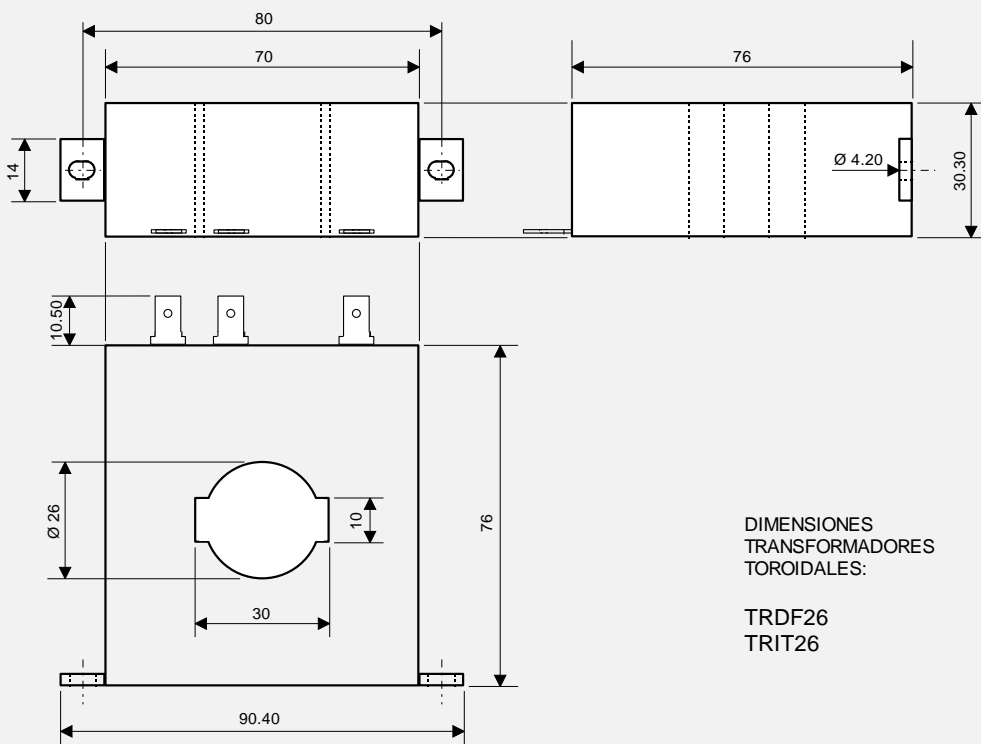
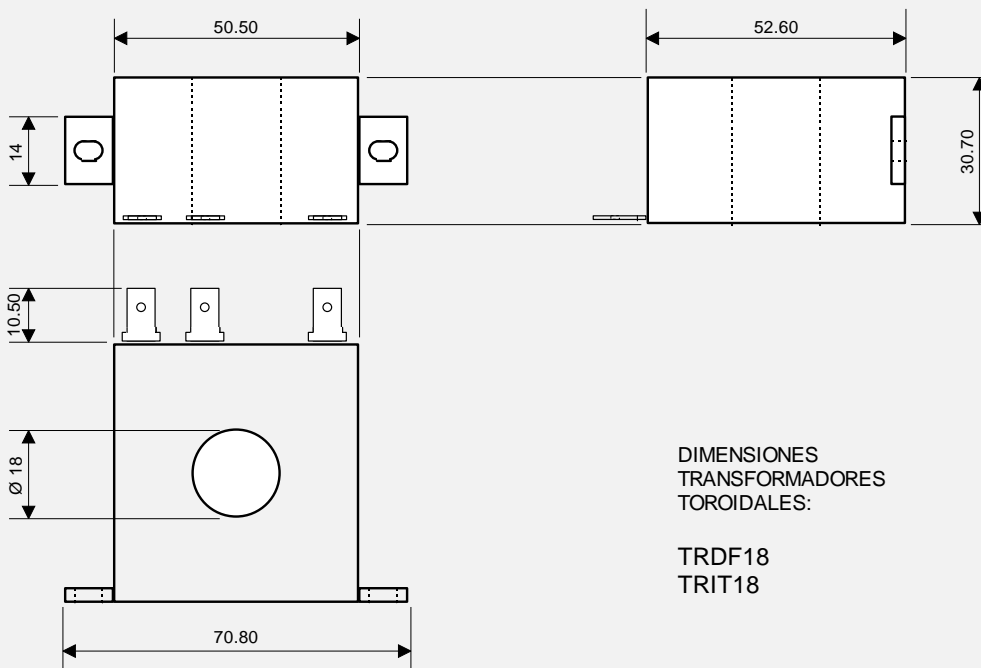

Chapter 16 – Modbus TCP/IP communication protocol , Port 502 (please, refer to synoptical tables of characteristics)

Modbus TCP/IP:

Modbus is a communication protocol located at layer 7 of the OSI Model, based on the master/slave or client/server architecture designed in 1979 by Modicon for its range of programmable logic controllers (PLC's). It has become a "de facto" standard within the industrial manufacturing environment and is the most widely used for the connection of industrial electronic devices.

The Modbus TCP/IP protocol transmits via Ethernet port 502.

For further information, consult the specifications and guidelines at "The Modbus Organization" website: <http://www.modbus.org/>.

1. Modbus messaging on TCP/IP implementation guide V1.0b
2. Modbus application protocol specification V1.1b3

Modbus supported commands

01 (0x01h)	Read Coils / Reading of digital outputs status
02 (0x02h)	Read Discrete Inputs / Reading of digital inputs status
04 (0x04h)	Read Input Registers / Reading of a register
05 (0x05h)	Write Single Coil / Writing of the status of a digital output
06 (0x06h)	Write Single Register / Writing of a register

Modbus tables

0:0001	Digital outputs (relays)	Commands: 01 and 05	Read / write
1:0001	Digital inputs	Command: 02	Read
3:0001	General measurements and values	Command: 04	Read
4:0001	Command	Command: 06	Write only

Types of data

Bit	Refers to binary
UWord16	Hexadecimal number, 16-bit unsigned integer, uses 1 memory address. Register with 2 bytes of memory in big-endian format. Example: 1234h will be sent as 12, 34. The most significant byte first.
Word16	Hexadecimal number, 16-bit signed integer, uses 1 memory address. Register with 2 bytes of memory in big-endian format. Example: 1234h will be sent as 12, 34. The most significant byte first.
UWord32	Hexadecimal number, 32-bit unsigned integer, uses 2 memory addresses. Register with 4 bytes of memory (2-word) in little-endian format. Example: 12345678h will be sent as 56, 78, 12, 34. The least significant word first.
UWord48	Hexadecimal number, 48-bit unsigned integer, uses 3 memory addresses. Register with 6 bytes of memory (3-word) in little-endian format. Example: 112233445566h will be sent as 55, 66, 33, 44, 11, 22. The least significant word first.
BCD16	Decimal number, 16-bit binary-coded, uses 1 memory address. Register with 2 bytes of memory in big-endian format. Used solely for writing user PIN. Varies from 0000 to 9999 decimal. Example: User PIN = 1234d, 1234h in BCD. Will be sent as 12, 34. The most significant byte first.

Table 3:0001, accessible with function code 0x04h (Read input registers).

Modbus registers (Dec)	Modbus addresses (Hex)	Nbr. of registers	Type of data	Description	Scaling	Units
Temperature and relative humidity						
1	0000	1	Word16	TEMP, Temperature	1/100	°C
2	0001	1	UWord16	HUME, Relative humidity	1/100	%Hr
Measurements						
3	0002	2	UWord32	VRMS1, RMS voltage L1	1/100	V
5	0004	2	UWord32	VRMS2, RMS voltage L2	1/100	V
7	0006	2	UWord32	VRMS3, RMS voltage L3	1/100	V
9	0008	2	UWord32	VPk1, Pk voltage L1	1/100	V
11	000A	2	UWord32	VPk2, Pk voltage L2	1/100	V
13	000C	2	UWord32	VPk3, Pk voltage L3	1/100	V
15	000E	1	UWord16	ID, RMS differential intensity	1/10	mA
16	000F	1	UWord16	IDPk, Pk differential intensity	1/10	mA
17	0010	2	UWord32	V12, RMS voltage phases L1 and L2	1/100	V
19	0012	2	UWord32	V23, RMS voltage phases L2 and L3	1/100	V
21	0014	2	UWord32	V31, RMS voltage phases L3 and L1	1/100	V
23	0016	2	UWord32	I1, RMS intensity L1	1/100	A
25	0018	2	UWord32	I2, RMS intensity L2	1/100	A
27	001A	2	UWord32	I3, RMS intensity L3	1/100	A
29	001C	2	UWord32	IPk1, Pk intensity L1	1/100	A
31	001E	2	UWord32	IPk2, Pk intensity L2	1/100	A
33	0020	2	UWord32	IPk3, Pk intensity L3	1/100	A
35	0022	1	UWord16	HZ1, Frequency L1	1/10	Hz
36	0023	1	UWord16	HZ2, Frequency L2	1/10	Hz
37	0024	1	UWord16	HZ3, Frequency L3	1/10	Hz
38	0025	2	UWord32	W1, Active power L1	1/10	W
40	0027	2	UWord32	W2, Active power L2	1/10	W
42	0029	2	UWord32	W3, Active power L3	1/10	W
44	002B	2	UWord32	W123, Sum L1+L2+L3	1/10	W
46	002D	2	UWord32	WP1, Requested power L1	1/10	W
48	002F	2	UWord32	WP2, Requested power L2	1/10	W
50	0031	2	UWord32	WP3, Requested power L3	1/10	W
52	0033	2	UWord32	WP123, Sum L1+L2+L3	1/10	W
54	0035	2	UWord32	WN1, Returned power L1	1/10	W
56	0037	2	UWord32	WN2, Returned power L2	1/10	W
58	0039	2	UWord32	WN3, Returned power L3	1/10	W
60	003B	2	UWord32	WN123, Sum L1+L2+L3	1/10	W
62	003D	2	UWord32	VA1, Apparent power L1	1/10	VA
64	003F	2	UWord32	VA2, Apparent power L2	1/10	VA
66	0041	2	UWord32	VA3, Apparent power L3	1/10	VA
68	0043	2	UWord32	VA123, Sum L1+L2+L3	1/10	VA
70	0045	2	UWord32	VARL1, Reactive inductive power L1	1/10	Var
72	0047	2	UWord32	VARL2, Reactive inductive power L2	1/10	Var
74	0049	2	UWord32	VARL3, Reactive inductive power L3	1/10	Var
76	004B	2	UWord32	VARL123, Sum L1+L2+L3	1/10	Var
78	004D	2	UWord32	VARC1, Reactive capacitive power L1	1/10	Var

80	004F	2	UWord32	VARC2, Reactive capacitive power L2	1/10	VAr
82	0051	2	UWord32	VARC3, Reactive capacitive power L3	1/10	VAr
84	0053	2	UWord32	VARC123, Sum L1+L2+L3	1/10	VAr
86	0055	1	UWord16	PF1, Power factor L1	1/1000	%
87	0056	1	UWord16	PF2, Power factor L2	1/1000	%
88	0057	1	UWord16	PF3, Power factor L3	1/1000	%
89	0058	1	UWord16	DESV1, Voltage unbalance L1	1/10	%
90	0059	1	UWord16	DESV2, Voltage unbalance L2	1/10	%
91	005A	1	UWord16	DESV3, Voltage unbalance L3	1/10	%
92	005B	1	UWord16	DESI1, Intensity unbalance L1	1/10	%
93	005C	1	UWord16	DESI2, Intensity unbalance L2	1/10	%
94	005D	1	UWord16	DESI3, Intensity unbalance L3	1/10	%
95	005E	2	UWord32	IN, neutral intensity	1/100	A
97	0060	1	UWord16	CFV1, Crest factor V1	1/1000	
98	0061	1	UWord16	CFV2, Crest factor V2	1/1000	
99	0062	1	UWord16	CFV3, Crest factor V3	1/1000	
100	0063	1	UWord16	CFI1, Crest factor I1	1/1000	
101	0064	1	UWord16	CFI2, Crest factor I2	1/1000	
102	0065	1	UWord16	CFI3, Crest factor I3	1/1000	
103	0066	2	UWord32	Z1, Impedance L1	1/100	
105	0068	2	UWord32	Z2, Impedance L2	1/100	
107	006A	2	UWord32	Z3, Impedance L3	1/100	
109	006C	2	UWord32	Maximeter W1	1/10	W
111	006E	2	UWord32	Maximeter W2	1/10	W
113	0070	2	UWord32	Maximeter W3	1/10	W

Measurements with harmonics (cf. Table 4:0001 to select channel and harmonic k)

115	0072	1	UWord16	THDV1, Harmonic distortion V1	1/10	%
116	0073	1	UWord16	THDV2, Harmonic distortion V2	1/10	%
117	0074	1	UWord16	THDV3, Harmonic distortion V3	1/10	%
118	0075	1	UWord16	THDI1, Harmonic distortion I1	1/10	%
119	0076	1	UWord16	THDI2, Harmonic distortion I2	1/10	%
120	0077	1	UWord16	THDI3, Harmonic distortion I3	1/10	%
121	0078	1	UWord16	FP1(k), Power factor harmonic k L1. $\cos\Phi_1$ if $k=1$.	1/1000	%
122	0079	1	UWord16	FP2(k), Power factor harmonic k L1. $\cos\Phi_2$ if $k=1$.	1/1000	%
123	007A	1	UWord16	FP3(k), Power factor harmonic k L1. $\cos\Phi_3$ if $k=1$.	1/1000	%
124	007B	2	UWord32	W1(k), Power harmonic k L1	1/10	W
126	007D	2	UWord32	W2(k), Power harmonic k L2	1/10	W
128	007F	2	UWord32	W3(k), Power harmonic k L3	1/10	W
130	0081	2	UWord32	W123(k), Sum L1+L2+L3	1/10	W
132	0083	2	UWord32	V1(k), Voltage harmonic k L1	1/100	V
134	0085	2	UWord32	V2(k), Voltage harmonic k L2	1/100	V
136	0087	2	UWord32	V3(k), Voltage harmonic k L3	1/100	V
138	0089	2	UWord32	I1(k), Intensity harmonic k L1	1/100	A
140	008B	2	UWord32	I2(k), Intensity harmonic k L2	1/100	A
142	008D	2	UWord32	I3(k), Intensity harmonic k L3	1/100	A
144	008F	2	UWord32	S1(k), Apparent power harmonic k L1	1/10	Var o S
146	0091	2	UWord32	S2(k), Apparent power harmonic k L2	1/10	Var o S
148	0093	2	UWord32	S3(k), Apparent power harmonic k L3	1/10	Var o S
150	0095	64	UWord16 * 64	HDF, Factor de harmonic distortion. $k = (0..63)$. (depending on channel selected)	1/10	%

AC-DC measurements – voltage, intensity and power (Please, go to end of table for differential intensity)

214	00D5	2	UWord32	V1dc, DC voltage L1	1/100	V
216	00D7	2	UWord32	V2dc, DC voltage L2	1/100	V
218	00D9	2	UWord32	V3dc, DC voltage L3	1/100	V
220	00DB	2	UWord32	I1dc, DC intensity L1	1/100	A
222	00DD	2	UWord32	I2dc, DC intensity L2	1/100	A
224	00DF	2	UWord32	I3dc, DC intensity L3	1/100	A
226	00E1	2	UWord32	V1ac, AC voltage L1	1/100	V
228	00E3	2	UWord32	V2ac, AC voltage L2	1/100	V
230	00E5	2	UWord32	V3ac, AC voltage L3	1/100	V
232	00E7	2	UWord32	I1ac, AC intensity L1	1/100	A
234	00E9	2	UWord32	I2ac, AC intensity L2	1/100	A
236	00EB	2	UWord32	I3ac, AC intensity L3	1/100	A
238	00ED	2	UWord32	P1dc, DC power L1	1/10	W
240	00EF	2	UWord32	P2dc, DC power L2	1/10	W
242	00F1	2	UWord32	P3dc, DC power L3	1/10	W
244	00F3	2	UWord32	P1ac, AC power L1	1/10	W
246	00F5	2	UWord32	P2ac, AC power L2	1/10	W
248	00F7	2	UWord32	P3ac, AC power L3	1/10	W

Maximum temperature and relative humidity

250	00F9	1	Word16	MAX_TEMP, Maximum TEMP	1/100	°C
251	00FA	1	UWord16	MAX_HUME, Maximum HUME	1/100	%Hr

Maximum measurements

252	00FB	2	UWord32	MAX_V1, Maximum V1	1/100	V
254	00FD	2	UWord32	MAX_V2, Maximum V2	1/100	V
256	00FF	2	UWord32	MAX_V3, Maximum V3	1/100	V
258	0101	1	UWord16	MAX_ID, Maximum ID	1/10	mA
259	0102	2	UWord32	MAX_I1, Maximum I1	1/100	A
261	0104	2	UWord32	MAX_I2, Maximum I2	1/100	A
263	0106	2	UWord32	MAX_I3, Maximum I3	1/100	A
265	0108	2	UWord32	MAX_IN, Maximum IN	1/100	A
267	010A	1	UWord16	MAX_HZ1, Maximum HZ1	1/10	Hz
268	010B	1	UWord16	MAX_HZ2, Maximum HZ2	1/10	Hz
269	010C	1	UWord16	MAX_HZ3, Maximum HZ3	1/10	Hz
270	010D	2	UWord32	MAX_MAXW1, Maximum Maximeter W1	1/10	W
272	010F	2	UWord32	MAX_MAXW2, Maximum Maximeter W2	1/10	W
274	0111	2	UWord32	MAX_MAXW3, Maximum Maximeter W3	1/10	W
276	0113	2	UWord32	MAX_VA1, Maximum VA1	1/10	VA
278	0115	2	UWord32	MAX_VA2, Maximum VA2	1/10	VA
280	0117	2	UWord32	MAX_VA3, Maximum VA3	1/10	VA
282	0119	2	UWord32	MAX_VARC1, Maximum VARC1	1/10	VAr
284	011B	2	UWord32	MAX_VARC2, Maximum VARC2	1/10	VAr
286	011D	2	UWord32	MAX_VARC3, Maximum VARC3	1/10	VAr
288	011F	2	UWord32	MAX_VARL1, Maximum VARL1	1/10	VAr
290	0121	2	UWord32	MAX_VARL2, Maximum VARL2	1/10	VAr
292	0123	2	UWord32	MAX_VARL3, Maximum VARL3	1/10	VAr
294	0125	1	UWord16	MAX_DESV1, Maximum DESV1	1/10	%
295	0126	1	UWord16	MAX_DESV2, Maximum DESV2	1/10	%
296	0127	1	UWord16	MAX_DESV3, Maximum DESV3	1/10	%

297	0128	1	UWord16	MAX_DESI1, Maximum DESI1	1/10	%
298	0129	1	UWord16	MAX_DESI2, Maximum DESI2	1/10	%
299	012A	1	UWord16	MAX_DESI3, Maximum DESI3	1/10	%
300	012B	1	UWord16	MAX_THDV1, Maximum THDV1	1/10	%
301	012C	1	UWord16	MAX_THDV2, Maximum THDV2	1/10	%
302	012D	1	UWord16	MAX_THDV3, Maximum THDV3	1/10	%
303	012E	1	UWord16	MAX_THDI1, Maximum THDI1	1/10	%
304	012F	1	UWord16	MAX_THDI2, Maximum THDI2	1/10	%
305	0130	1	UWord16	MAX_THDI3, Maximum THDI3	1/10	%
Minimum temperature and relative humidity						
306	0131	1	Word16	MIN_TEMP, Minimum TEMP	1/100	°C
307	0132	1	UWord16	MIN_HUME, Minimum HUME	1/100	%Hr
Minimum measurements						
308	0133	2	UWord32	MIN_V1, Minimum V1	1/100	V
310	0135	2	UWord32	MIN_V2, Minimum V2	1/100	V
312	0137	2	UWord32	MIN_V3, Minimum V3	1/100	V
314	0139	1	UWord16	MIN_HZ1, Minimum HZ1	1/10	Hz
315	013A	1	UWord16	MIN_HZ2, Minimum HZ2	1/10	Hz
316	013B	1	UWord16	MIN_HZ3, Minimum HZ3	1/10	Hz
Energy counters						
317	013C	3	UWord48	KWH1+, Active imported energy counter L1	1/100000	kWh1+
320	013F	3	UWord48	KWH2+, Active imported energy counter L2	1/100000	kWh2+
323	0142	3	UWord48	KWH3+, Active imported energy counter L3	1/100000	kWh3+
326	0145	3	UWord48	KWH123+, Sum L1+L2+L3	1/100000	kWh+
329	0148	3	UWord48	KWH1-, Active exported energy counter L1	1/100000	kWh1-
332	014B	3	UWord48	KWH2-, Active exported energy counter L2	1/100000	kWh2-
335	014E	3	UWord48	KWH3-, Active exported energy counter L3	1/100000	kWh3-
338	0151	3	UWord48	KWH123-, Sum L1+L2+L3	1/100000	kWh-
341	0154	3	UWord48	KQH1, Reactive energy counter L1	1/100000	kQh1
344	0157	3	UWord48	KQH2, Reactive energy counter L2	1/100000	kQh2
347	015A	3	UWord48	KQH3, Reactive energy counter L3	1/100000	kQh3
350	015D	3	UWord48	KQH123, Sum L1+L2+L3	1/100000	kQh
Cut-off counters by type <i>(Alarm counters in Command 1)</i>						
353	0160	1	UWord16	CN_STEMP, Over-temperature cut-off counter		
354	0161	1	UWord16	CN_ITEMP, Low temperature cut-off counter		
355	0162	1	UWord16	CN_SHUME, Over-humidity cut-off counter		
356	0163	1	UWord16	CN_IHUME, Low humidity cut-off counter		
357	0164	1	UWord16	CN_ST1, Cut-off counter over V1		
358	0165	1	UWord16	CN_ST2, Cut-off counter over V2		
359	0166	1	UWord16	CN_ST3, Cut-off counter over V3		
360	0167	1	UWord16	CN_IT1, Cut-off counter low V1		
361	0168	1	UWord16	CN_IT2, Cut-off counter low V2		
362	0169	1	UWord16	CN_IT3, Cut-off counter low V3		
363	016A	1	UWord16	CN_I1, Cut-off counter I1		
364	016B	1	UWord16	CN_I2, Cut-off counter I2		
365	016C	1	UWord16	CN_I3, Cut-off counter I3		
366	016D	1	UWord16	CN_ID, Cut-off counter ID		
367	016E	1	UWord16	CN_DESV1, Cut-off counter DESV1		

368	016F	1	UWord16	CN_DESV2, Cut-off counter DESV2		
369	0170	1	UWord16	CN_DESV3, Cut-off counter DESV3		
370	0171	1	UWord16	CN_DESI1, Cut-off counter DESI1		
371	0172	1	UWord16	CN_DESI2, Cut-off counter DESI2		
372	0173	1	UWord16	CN_DESI3, Cut-off counter DESI3		
373	0174	1	UWord16	CN_INEUTRO, Cut-off counter INEUTRO		
374	0175	1	UWord16	CN_VA1, Cut-off counter POTENCIA VA1		
375	0176	1	UWord16	CN_VA2, Cut-off counter POTENCIA VA2		
376	0177	1	UWord16	CN_VA3, Cut-off counter POTENCIA VA3		
377	0178	1	UWord16	CN_W1, Cut-off counter POTENCIA W1		
378	0179	1	UWord16	CN_W2, Cut-off counter POTENCIA W2		
379	017A	1	UWord16	CN_W3, Cut-off counter POTENCIA W3		
380	017B	1	UWord16	CN_THDV1, Cut-off counter THDV1		
381	017C	1	UWord16	CN_THDV2, Cut-off counter THDV2		
382	017D	1	UWord16	CN_THDV3, Cut-off counter THDV3		
383	017E	1	UWord16	CN_THDI1, Cut-off counter THDI1		
384	017F	1	UWord16	CN_THDI2, Cut-off counter THDI2		
385	0180	1	UWord16	CN_THDI3, Cut-off counter THDI3		
386	0181	1	UWord16	CN_SHZ1, Cut-off counter over HZ1		
387	0182	1	UWord16	CN_SHZ2, Cut-off counter over HZ2		
388	0183	1	UWord16	CN_SHZ3, Cut-off counter over HZ3		
389	0184	1	UWord16	CN_IHZ1, Cut-off counter low HZ1		
390	0185	1	UWord16	CN_IHZ2, Cut-off counter low HZ2		
391	0186	1	UWord16	CN_IHZ3, Cut-off counter low HZ3		
392	0187	1	UWord16	CN_PF1, Cut-off counter PF1		
393	0188	1	UWord16	CN_PF2, Cut-off counter PF2		
394	0189	1	UWord16	CN_PF3, Cut-off counter PF3		
395	018A	1	UWord16	CN_SF, Cut-off counter: phase sequence		
396	018B	1	UWord16	CN_MCB, Cut-off counter: MCB		
397	018C	1	UWord16	CN_PH, Cut-off counter: time programmer		
398	018D	1	UWord16	CN_RIN1, Cut-off counter: Remote input 1		
399	018E	1	UWord16	CN_RIN2, Cut-off counter: Remote input 2		
400	018F	1	UWord16	CN_BLOCK, Block counter		
401	0190	1	UWord16	CN_POFF, Cut-off counter: power failure 230Vac		
402	0191	1	UWord16	CN_TOTAL, Sum of all the counters		
403	0192	1	UWord16	CN_ACCUM, Cut-off counter (undeletable)		
Counters: transients/dips per line						
404	0193	1	UWord16	CN_TH_L1, Counter; transients/dips in L1		
405	0194	1	UWord16	CN_TH_L2, Counter; transients/dips in L2		
406	0195	1	UWord16	CN_TH_L3, Counter; transients/dips in L3		
Status digital outputs, internal relays A and B <i>(Also accessible from table 0:0001, read/write)</i>						
407	0196	1	UWord16	Bit 0, Status of relay A Bit 1, Status of relay B		
Status digital outputs, external modules 1 and 2 <i>(Also accessible from table 0:0001, read/write)</i>						

408	0197	1	UWord16	Bit 0, Status of relay 1 external module 1 Bit 1, Status of relay 2 external module 1 Bit 2, Status of relay 3 external module 1 Bit 3, Status of relay 4 external module 1 Bit 4, Status of relay 1 external module 2 Bit 5, Status of relay 2 external module 2 Bit 6, Status of relay 3 external module 2 Bit 7, Status of relay 4 external module 2		
Status digital inputs, external modules 1 and 2 (Also accessible from table 1:0001, read)						
409	0198	1	UWord16	Bit 0, Status of input 1 external module 1 Bit 1, Status of input 2 external module 1 Bit 2, Status of input 3 external module 1 Bit 3, Status of input 4 external module 1 Bit 4, Status of input 1 external module 2 Bit 5, Status of input 2 external module 2 Bit 6, Status of input 3 external module 2 Bit 7, Status of input 4 external module 2		
Status digital inputs, remote inputs 1 and 2 (Also accessible from table 1:0001, read)						
410	0199	1	UWord16	Bit 0, Status remote input 1 Bit 1, Status remote input 2		
AC-DC measurements – differential intensity						
411	019A	1	UWord16	ID, differential intensity - AC	1/10	mA
412	019B	1	UWord16	ID, differential intensity - DC	1/10	mA

Table 4:0001, accessible with function code 0x06h (**Write** single register).

Writing in logs 2 to 10 will only be effective if the user PIN has been previously written in log 1 otherwise the function will show error with exception code 0x01h. In order to delete the user PIN, re-write log 1 as a value of 0x0000h.

Modbus registers (Dec)	Modbus addresses (Hex)	Nbr Registers	Type data	Description
User PIN				
1	0000	1	BCD16	User PIN / Password
Commands				
2	0001	1	UWord16	= 0x0000h, Reset maximum measurements and maximeters W1 W2 W3
3	0002	1	UWord16	= 0x0000h, Reset minimum measurements
4	0003	1	UWord16	= 0x0000h, Reset to zero of energy counters
5	0004	1	UWord16	= 0x0000h, Reset to zero of cut-off counters
6	0005	1	UWord16	= 0x0000h, Unblocking and reset of reclosures
7	0006	1	UWord16	Selector harmonic k. $0x0000h \leq k \leq 0x003Fh$ Measurement V, I, W and FP/Cosfi(k=1) of harmonic k.
8	0007	1	UWord16	Selector channel measurement harmonic distortion factor V1=00h, V2=02h, V3=04h, I1=06h, I2=08h, I3=0Ah. Measurement of all harmonics from 0 to 63
9	0008	1	UWord16	Bit 0 = 1, Disable internal relay A Bit 1 = 1, Disable internal relay B Bit 2 Bit 3 Bit 4 Bit 5 Bit 6 Bit 7 Bit 8 = 1, Enable internal relay A Bit 9 = 1, Enable internal relay B Bit A Bit B Bit C Bit D Bit E Bit F

10	0009	1	UWord16	Bit 0 = 1, Disable relay 1 of external module 1 Bit 1 = 1, Disable relay 2 of external module 1 Bit 2 = 1, Disable relay 3 of external module 1 Bit 3 = 1, Disable relay 4 of external module 1 Bit 4 = 1, Disable relay 1 of external module 2 Bit 5 = 1, Disable relay 2 of external module 2 Bit 6 = 1, Disable relay 3 of external module 2 Bit 7 = 1, Disable relay 4 of external module 2 Bit 8 = 1, Enable relay 1 of external module 1 Bit 9 = 1, Enable relay 2 of external module 1 Bit A = 1, Enable relay 3 of external module 1 Bit B = 1, Enable relay 4 of external module 1 Bit C = 1, Enable relay 1 of external module 2 Bit D = 1, Enable relay 2 of external module 2 Bit E = 1, Enable relay 3 of external module 2 Bit F = 1, Enable relay 4 of external module 2
----	------	---	---------	--

Table 0:0001, accessible with function code 0x01h (**Read Coils**) and 0x05h (**Write Single Coil**).

Writing in registers from 1 to 16 will only be effective if the user PIN has previously been written in register 1 of table 4:0001. If this is not done, then the function returns error with exception code 0x01h.

In order to delete the user PIN, re-write log 1 as a value of 0x0000h.

Modbus registers (Dec)	Modbus addresses (Hex)	Nbr registers	Type data	Description
Digital outputs, internal relays A and B				
1	0000	1	Bit	Internal relay A
2	0001	1	Bit	Internal relay B
3	0002	1	Bit	Reserved (Bit at 0)
4	0003	1	Bit	Reserved (Bit at 0)
5	0004	1	Bit	Reserved (Bit at 0)
6	0005	1	Bit	Reserved (Bit at 0)
7	0006	1	Bit	Reserved (Bit at 0)
8	0007	1	Bit	Reserved (Bit at 0)
Digital outputs, external modules 1 and 2				
9	0008	1	Bit	Relay 1 external module 1
10	0009	1	Bit	Relay 2 external module 1
11	000A	1	Bit	Relay 3 external module 1
12	000B	1	Bit	Relay 4 external module 1
13	000C	1	Bit	Relay 1 external module 2
14	000D	1	Bit	Relay 2 external module 2
15	000E	1	Bit	Relay 3 external module 2
16	000F	1	Bit	Relay 4 external module 2

Table 1:0001, accessible with function code 0x02h (**Read Discrete Input**).

Modbus registers (Dec)	Modbus addresses (Hex)	Nbr registers	Type data	Description
Status digital inputs, remote inputs 1 and 2				
1	0000	1	Bit	Remote input 1
2	0001	1	Bit	Remote input 2
3	0002	1	Bit	Reserved (Bit at 0)
4	0003	1	Bit	Reserved (Bit at 0)
5	0004	1	Bit	Reserved (Bit at 0)
6	0005	1	Bit	Reserved (Bit at 0)
7	0006	1	Bit	Reserved (Bit at 0)
8	0007	1	Bit	Reserved (Bit at 0)

Status digital inputs, external modules 1 and 2				
9	0008	1	Bit	Input 1 external module 1
10	0009	1	Bit	Input 2 external module 1
11	000A	1	Bit	Input 3 external module 1
12	000B	1	Bit	Input 4 external module 1
13	000C	1	Bit	Input 1 external module 2
14	000D	1	Bit	Input 2 external module 2
15	000E	1	Bit	Input 3 external module 2
16	000F	1	Bit	Input 4 external module 2

Chapter 17 – TCP/IP. HTTP communication protocol. WebServer.

There are numerous TCP/IP commands which can be sent to a remote unit from the address bar of any browser or via a software program customised to the owner's requirements. These commands must be sent to the address and IP port of the remote unit and, in order to be effective, must include the user PIN configured for the remote unit to which these commands are destined

1. Receive complete list of measurements , LOG and I/O status in .txt format
2. Enable / disable internal relays A and B
3. Enable / disable relays 1,2,3,4 of external module 1
4. Enable / disable relays 1,2,3,4 of external module 2
5. Unblocking of unit and reset of all reclosure cycles

Please refer to appendix "TCP/IP. HTTP communication protocol. WebServer".

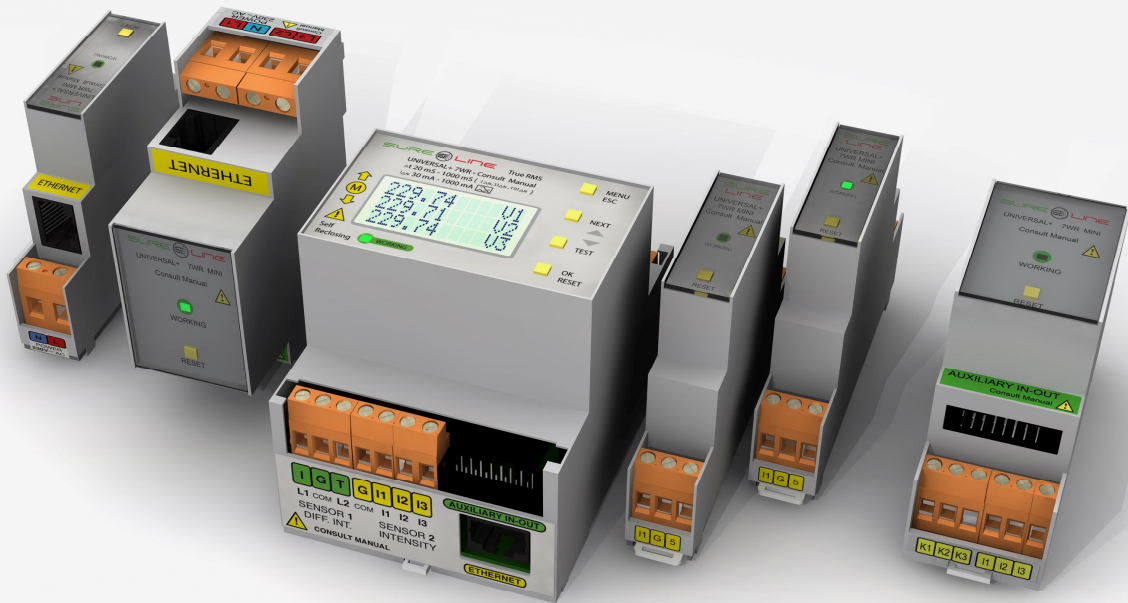

SAFELINE, S.L.

Edificio Safeline

Cooperativa, 24
E 08302 MATARO
(Barcelona) SPAIN
www.safeline.es
safeline@safeline.es

Commercial

T. +34 938841820
T. +34 937630801
comercial@safeline.es

Factory, R + D

T. +34 937411010
T. +34 607409841
inves@safeline.es

Administration

T. +34 937630801
T. +34 607409841
admin@safeline.es

Made in EU

